

R.P. ADAMS

A SUBSIDIARY OF SERVICE FILTRATION CORPORATION



S i m p l e x
B a s k e t S t r a i n e r s

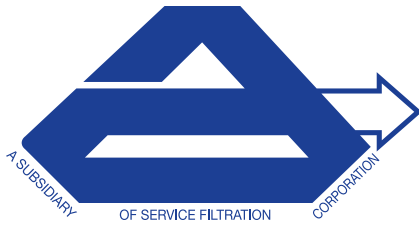

Table Of Contents

RPA Simplex Basket Strainers

Simplex Basket Strainers	2
RPA Series B125 and B300 Style 2 Threaded and Socket Weld Basket Strainers	3
RPA Series B125F and B150F Style 1 Iron and Bronze Flanged Basket Strainers	5
RPA Series B150F Style 1 Cast Steel Flanged Basket Strainers	7
RPA Series B150F Style 2 Cast Steel Flanged Basket Strainers	9
Quick Opening Covers	11
Replacement Baskets	13

Engineering Data

Screen Openings for Basket Strainers	14
Basket Strainer Pressure Drop - Liquids	15
Screen Correction Factor Chart	16
Correction Factors for Clogged Screens	17
Basket Strainer Basket Burst Pressure	18
Basket Strainer Effective Area	19
Check List and Suggested Specifications	20
Installation and Maintenance Instructions	21
How To Order	22

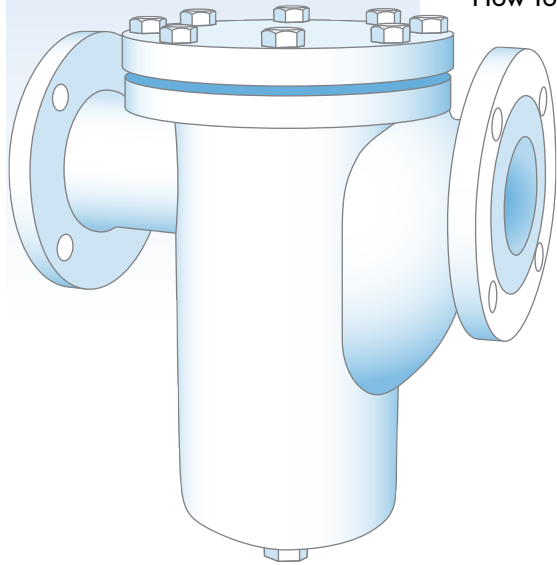

Notes: The material in this catalogue is for general information. For specific performance data and proper material selection, consult factory or your RPA representative. Although every attempt has been made to ensure that the information contained in this catalogue is correct RPA Inc. reserves the right to change designs, materials and/or specifications without notice.

Limited Warranty

All products are warranted to be free of defects in material and workmanship for a period of one year from the date of shipment, subject to the limitations below: If the purchaser believes a product defective, the purchaser shall: **(a)** Notify the manufacturer, state the alleged defect and request permission to return the product. **(b)** If permission is given, return the product with transportation prepaid. If the product is accepted for return and found to be defective, the manufacturer will, at its discretion, either repair or replace the product, f.o.b. factory, within 60 days of receipt, or refund the purchase price.

Other than to repair, replace or refund described above, the purchaser agrees that the manufacturer shall not be liable for any losses, costs, expenses or damages of any kind arising out of the product, its use, installation or replacement, labeling, instructions, information or technical data of any kind, description of product use, sample or model, warnings or lack of foregoing. No other warranties, written or oral, expressed or implied, including the warranties of fitness for a particular purpose and merchantability, are made or authorized.

No affirmation of fact, promise, description of product use or sample or model shall create any warranty from the manufacturer, unless signed by the president. These products are not manufactured, sold or intended for personal, family or household purposes.

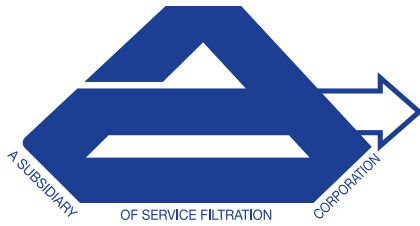

Simplex Basket Strainers

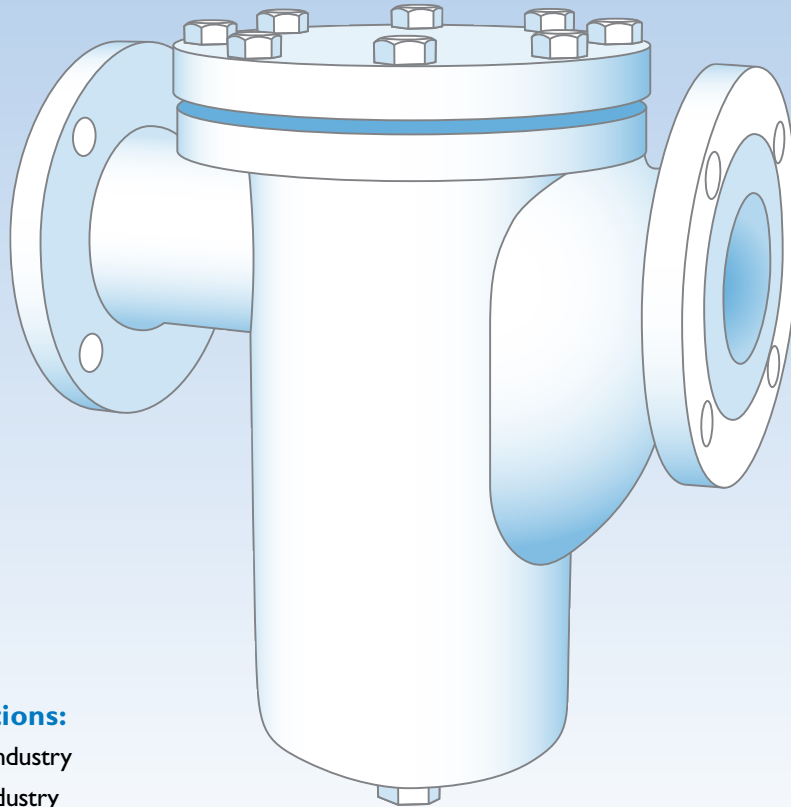

Applications:

- Process Industry
- Power Industry
- Chemical Industry
- Oil and Gas
- Pulp and Paper
- Metals and Mining
- Water and Waste

Size Range:

- 1/2" - 20" (15mm - 500mm)

End Connections:

- Flat Faced (FF)
- Raised Face (RF)
- Butt-weld (BW)
- Threaded (NPT)
- Socket Weld (SW)

Features:

- Filtration level to 40 microns.
- Generously sized strainer baskets.
- Both compact and high capacity units are available.

Available Materials of Construction:

- Cast Iron
- Bronze
- Carbon Steel
- Stainless Steel

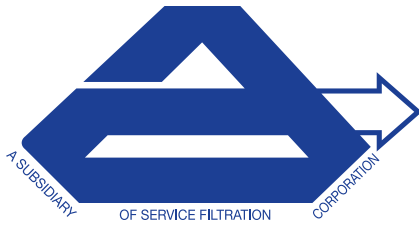

RPA Series B125 and B300 Style 2 Threaded and Socket Weld Basket Strainers

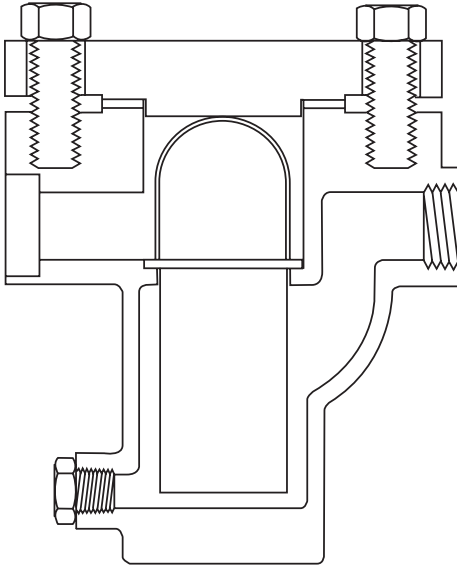

Design Features:

- Strainers are equipped with threaded (NPT) or socket weld inlet/outlet connections.
- Strainer body meets applicable ASME Standard.
- RPA series B300 strainers equipped with bolted cover flanges that utilize a flat gasket seal.
- RPA series B125 strainers equipped with a rotating cover that utilizes an O-Ring seal.
- Strainer cover flanges are designed in accordance with ASME Section VIII, Div. I Appendix II and/or ASME B16.5.
- Over-the-top flow design complete with machined basket seats eliminates the possibility of dirty fluid by-pass.
- Standard basket construction is 304 SS perforated plate.
- Recommended lower straining level is 40 microns.
- N.P.T. drain connection furnished with plug.
- Recommended for installation in horizontal pipelines.
- Generous screen area and properly proportioned outer annulus minimize pressure drop while maximizing time between cleanings.

- Notes:** 1. See page 11 for details of available quick opening covers.
2. See page 19 for basket strainer effective areas.

Parts List and Standard Materials

Part	Cast Iron	Carbon Steel	Stainless Steel
Body	A126-B	A216-WCB	A351-CF8M
Cover	A126-B	A216-WCB	A351-CF8M
Screen ¹	304SS	304SS	304SS
Plug ²	A126-B	A105	A182-316
Gasket ¹	Buna-N O-Ring	Bolted Cover: 304SS Spiral Wound Quick Opening: See pg. 11	Bolted Cover: 304SS Spiral Wound Quick Opening: See pg. 11
Bolt/Stud ²	A307-B	A193-B7	A193-B8-1
Nut ²	A563	A194-2H	A194-8

- Notes:** 1. Recommended Spares.
2. Materials of equivalent strength may be substituted at manufacturer's option.

Upper Pressure Limits (Non-Shock)

RPA Model (Threaded)	Body Material	M.A.W.P. psig (Bars)
B125TIB2	A126B	200 (13.79)
B300TSB2	WCB	740 (51.02)
B300TSSB2	CF8M	720 (49.64)

Lower Temperature Limits

Body Material	Lower Limit $^{\circ}$ F ($^{\circ}$ C)
A126-B	-20 (-28.9)
WCB	-20 (-28.9)
CF8M	-20 (-28.9)

Pressure Temperature Chart (in accordance with ASME B16.1 & ASME B16.5, WCB)

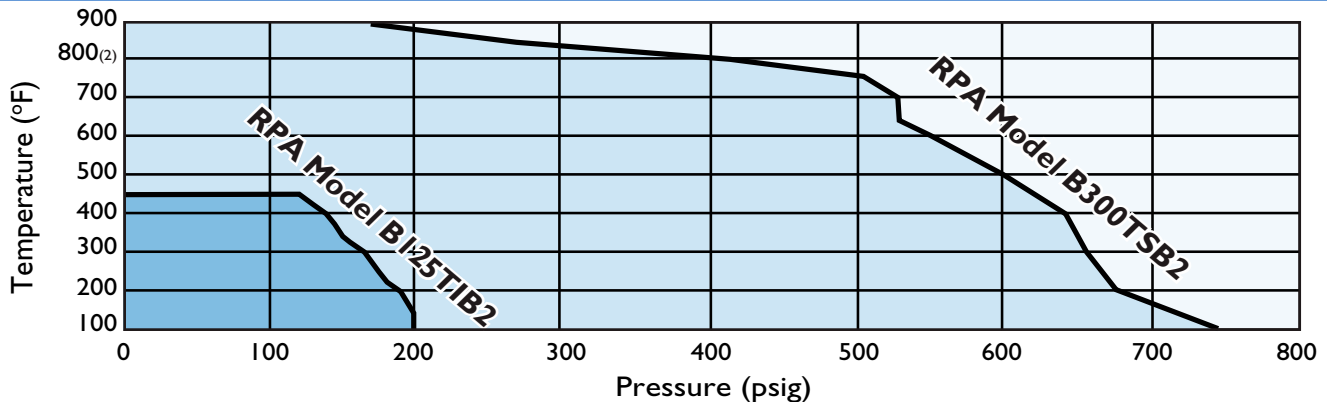

- Notes:** 1. Graphite filled 304 SS Spiral Wound gaskets limited to 900°F in an oxidizing atmosphere. When operating RPA Series 300B strainers at higher temperatures please consult factory.
2. Upon prolonged exposure to temperatures above 800°F, the carbide phase of carbon steel may be converted to graphite.

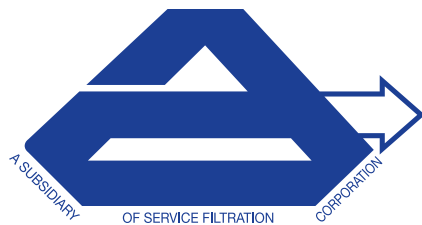

RPA Series B125 and B300 Style 2 Threaded and Socket Weld Basket Strainers

Standard Screens

Size range **Opening**

1/2" - 1 1/2" 0.032 in.

15mm - 40mm 0.8 mm

2" 0.045 in.

50mm 1.2 mm

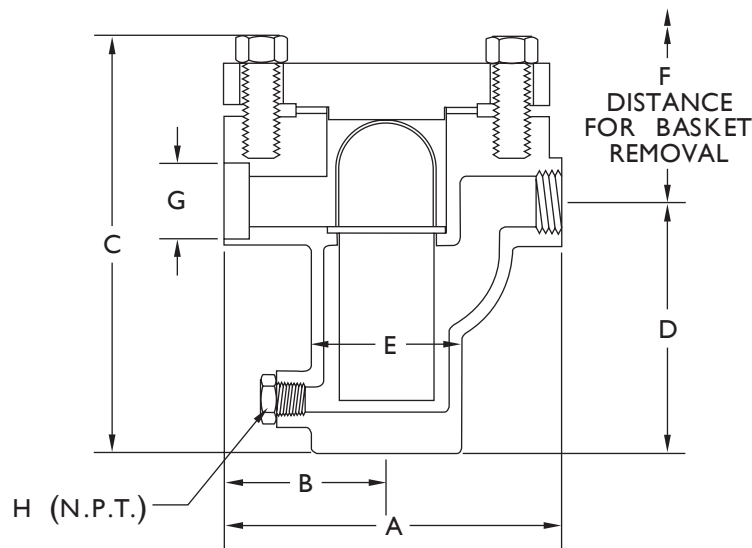

Dimensional Data (Class 125-300)

Size in (mm)	A in (mm)		B in (mm)		C in (mm)		D in (mm)		E in (mm)	F in (mm)		G in (mm)	H NPT in (mm)		Weight Lb./ (Kg.) Cover		Unit	
	B125	B300	B125	B300	B125	B300	B125	B300		B125	B300		B300	B125	B300	B125	B300	B125
1/2	6.75	6.13	3.50	3.06	8.50	7.06	5.38	4	3.63	7.13	5.75	0.855	3/8	3/8	3	6	10	18
15	171	156	89	78	216	179	137	102	92	181	146	21.72	10	10	1.4	2.7	4.5	8.2
3/4	6.75	6.75	3.50	3.25	8.50	8.38	5.38	5	3.63	7.88	7.44	1.065	1/2	3/8	6	8	18	24
20	171	171	89	83	216	213	137	127	92	200	189	27.05	15	10	2.7	3.6	8.2	10.9
1	6.75	6.75	3.50	3.25	8.50	8.38	5.38	5	3.63	7.88	7.44	1.330	1/2	1/2	6	8	18	24
25	171	171	89	83	216	213	137	127	92	200	189	33.78	15	15	2.7	3.6	8.2	10.9
1 1/4	8.50	8.13	4.13	3.75	10.75	11.88	7.13	7.75	4.25	10.50	11.06	1.675	1/2	3/4	8	12	30	43
32	216	206	105	95	273	302	181	197	108	267	281	42.55	15	20	3.6	5.4	13.6	19.5
1 1/2	8.50	8.13	4.13	3.75	10.75	11.88	7.13	7.75	4.25	10.50	11.06	1.915	3/4	3/4	8	12	30	43
40	216	206	105	95	273	302	181	197	108	267	281	48.64	20	20	3.6	5.4	13.6	19.5
2	9.75	9.00	4.50	4.13	10.75	12.38	7.13	7.75	5.25	11.00	11.69	2.406	1 1/4	1	13	16	50	50
50	248	229	114	105	273	314	181	197	133	279	297	61.11	32	25	5.9	7.3	22.7	26.3
2 1/2	11.50	N/A	5.25	N/A	15.25	N/A	9.13	N/A	6.63	13.25	N/A	N/A	1 1/4	N/A	17	N/A	62	N/A
	2 9 2		3 53 61		7 8 3		2 3 2			7 3 3		8 6	2 3		7 . 7		1 . 8 2	
3	11.50	N/A	5.25	N/A	15.25	N/A	9.13	N/A	6.63	13.50	N/A	N/A	1 1/4	N/A	17	N/A	62	N/A
	2 9 2		3 03 81		7 8 3		2 3 2			3 4 3		8 6	2 3		7 . 7		1 . 8 2	

- Notes:**
1. Vents are optional.
 2. Dimension "C" will change when Quick Opening covers are used.
 3. RPA Series B125 strainers are only available with a style R rotating cover.
 4. RPA Series B125 strainers are complete with bottom drains.
 5. RPA Series B300 strainers are complete with side drains, bottom drains are optional.
 6. Dimension "G" applies to RPA series B300 only.
 7. Dimensions shown are subject to change. Consult factory for certified prints when required.

General

1. Quick opening cover features are shown on pages 11-12.
2. See pg. 14 for available perforations and screen materials.
3. Pressure drop information is shown on pg. 15.
4. See pg. 22 for ordering information.
5. Dimensions shown are subject to change. Consult factory for certified prints when required.

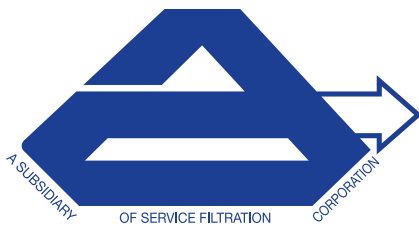

RPA Series BI25F and BI50F Style I Iron and Bronze Flanged Basket Strainers

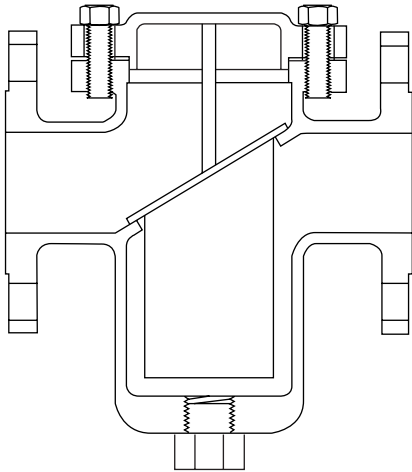

Design Features:

- Iron strainers are equipped with FF flanges (Series BI25F) in accordance with ASME B16.1.
- Bronze strainers are equipped with FF flanges (Series BI50F) in accordance with ASME B16.24.
- Strainer body meets applicable ASME/ANSI standard.
- All strainers equipped with bolted cover flanges that utilize a flat gasket seal.
- Strainer cover flanges are designed in accordance with ASME Section VIII, Div.I Appendix II.
- Straight thru flow is accomplished by an angular basket design.
- Standard basket construction is 304 SS perforated plate.
- Recommended minimum straining level is 250 microns.
- N.P.T. drain connection furnished with plug.
- Recommended for installation in horizontal pipelines.

- Notes:**
1. See page 11 for details of available quick opening covers.
 2. See page 19 for basket strainer effective areas.

Parts List and Standard Materials

Part RPA Model	Cast Iron BI25FIBI	Bronze BI50FBBI
Body	A126-B	B62
Cover	A126-B	B62
Screen ¹	304 SS	304 SS
Plug ²	A126-B	B62
Gasket ¹	Bolted Cover: Graphite Quick Opening: See pg. 11	Bolted Cover: Teflon Quick Opening: See pg. 11
Bolt/Stud ²	A307-B	Nonferrous
Nut ²	A563	Nonferrous

- Notes:**
1. Recommended spares.
 2. Materials of equivalent strength may be substituted at manufacturer's option.

Upper Pressure Limits (Non-Shock)

RPA Model	Body Material	M.A.W.P. psig (Bars)
BI25FIBI (Up to 12" size)	A126-B	200 (13.79)
BI25FIBI (Sizes 14" and up)	A126-B	150 (10.34)
BI50FBBI	B62	225 (15.51)

Lower Temperature Limits

Body Material	Lower Limit °F (°C)
A126-B, B62	-20 (-28.9)

Pressure Temperature Chart (in accordance with ASME B16.1 & ASME B16.24)

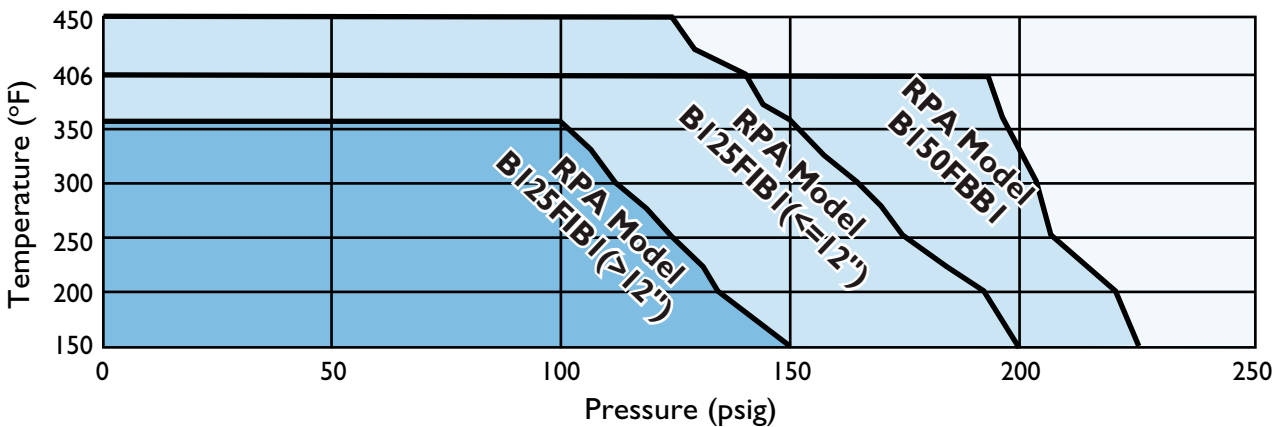

Note: Max. rating temperature for RPA model BI50FBBI limited by codes such as ASME B31.1, ASME B31.5, etc.

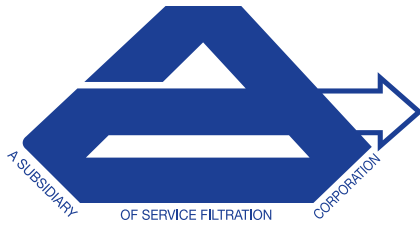

RPA Series BI25F and BI50F Style I Iron and Bronze Flanged Basket Strainers

Standard Screens

Size range **Opening**

2 - 3" 0.045 in.

50mm - 80mm 1.2 mm

4" - 20" 0.125 in.

100mm - 500mm 3.2 mm

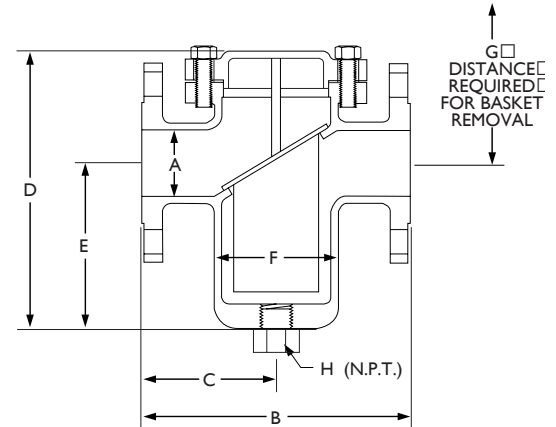

Dimensional Data (Class 125-150)

Size in (mm)	A in (mm)	B in (mm)	C in (mm)	D in (mm)	E in (mm)	F in (mm)	G in (mm)	H NPT		Weight	
								in/mm	in/mm	Lb./	(Kg.)
2"	2.00	8.13	4.06	8.38	5.00	3.00	11.75	1/2	1	5	23
50	51	206	103	213	127	76	298	15	25	2.3	10
2 1/2"	2.50	8.25	4.13	9.75	6.25	4.00	13.25	3/4	1	7	33
65	64	210	105	248	159	102	337	20	25	3.2	15
3"	3.00	9.88	4.94	11.25	7.13	5.00	15.38	3/4	1	9	44
80	76	251	125	286	181	127	391	20	25	4.1	20
4"	4.00	11.50	5.75	12.88	8.00	6.00	17.75	1	1	13	67
100	102	292	146	327	203	152	451	25	25	5.9	30
5"	5.00	13.13	6.56	14.50	8.50	6.50	20.50	1	1	20	88
125	127	333	167	368	216	165	521	25	25	9.1	40
6"	6.00	14.88	7.44	16.00	9.00	8.00	23.00	1	1	26	120
150	152	378	189	406	229	203	584	25	25	12	54
8"	8.00	18.75	9.38	21.00	12.00	10.00	30.00	1 1/2	N/A	45	220
200	203	476	238	533	305	254	762	40		20	100
10"	10.00	20.00	10.00	24.75	14.00	12.50	35.50	1 1/2	N/A	70	353
250	254	508	254	629	356	318	902	40		32	160
12"	12.00	26.25	13.13	29.75	17.00	15.00	42.50	1 1/2	N/A	110	523
300	305	667	333	756	432	381	1080	40		50	237
14"	14.00	30.25	15.13	37.50	22.00	18.00	53.00	1 1/2	N/A	140	815
350	356	768	384	953	559	457	1346	40		64	370
16"	16.00	33.25	16.63	39.25	22.88	20.75	55.63	1 1/2	N/A	180	1041
400	406	845	422	997	581	527	1413	40		82	472
18"	18.00	38.50	19.25	40.00	19.00	24.25	61.00	2	N/A	220	1446
450	457	978	489	1016	483	616	1549	50		100	656
20"	20.00	41.38	20.69	46.25	23.25	26.50	69.25	2	N/A	285	1980
500	508	1051	525	1175	591	673	1759	50		129	898

- Notes:**
1. Vents are optional.
 2. Dimension "B" is +/- 0.13".
 3. Dimension "D" will change when Quick Opening covers are used.
 4. Sizes 8" and larger come complete with a side drain as standard. A bottom drain is optional.

General

1. Quick opening cover features are shown on pages 11-12.
2. See pg. 14 for available perforations and screen materials.
3. Pressure drop information is shown on pg. 15.
4. See pg. 22 for ordering information.
5. Dimensions shown are subject to change. Consult factory for certified prints when required.

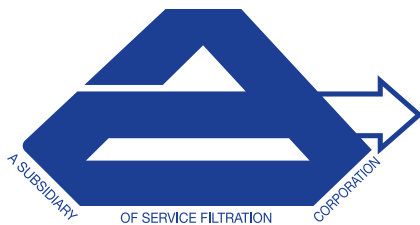

RPA Series B150F Style I Cast Steel Flanged Basket Strainers

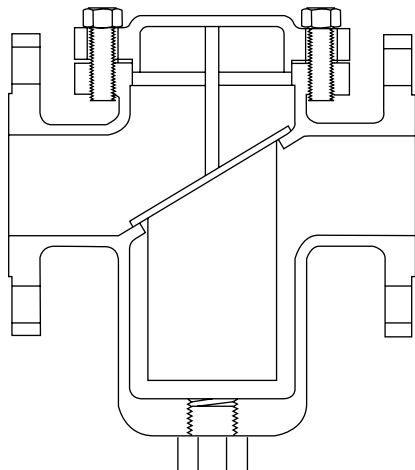

Design Features:

- Strainers are equipped with RF flanges in accordance with ASME B16.5.
- Strainer body meets ASME B16.5 and ASME B16.34.
- All strainers equipped with bolted cover flanges that utilize a flat gasket seal.
- Strainer cover flanges are designed in accordance with ASME Section VIII, Div. I Appendix II.
- Straight thru flow is accomplished by an angular basket design.
- Standard basket construction is 304 SS perforated plate.
- Recommended minimum straining level is 250 microns.
- N.P.T. drain connection furnished with plug.
- Recommended for installation in horizontal pipelines.

- Notes:** 1. See page 11 for details of available quick opening covers.
2. See page 19 for basket strainer effective areas.

Parts List and Standard Materials

Part	Carbon Steel RPA Model B150FSBI	Stainless Steel B150FSSBI
Body	A216-WCB	A351-CF8M
Cover	A216-WCB	A351-CF8M
Screen ¹	304SS	304SS
Plug ²	A105	A182-316
Gasket ¹	Bolted Cover: Teflon Quick Opening: See pg. 11	Bolted Cover: Teflon Quick Opening: See pg. 11
Bolt/Stud ²	A193-B7	A193-B8-1
Nut ²	A194-2H	A194-8

Upper Pressure Limits (Non-Shock)

RPA Model	Body Material	M.A.W.P. psig (Bars)
B150FSBI	WCB	285 (19.65)
B150FSSBI	CF8M	275 (18.96)

Lower Temperature Limits

Body Material	Lower Limit ;F (;C)
WCB	-20 (-28.9)
CF8M	-20 (-28.9)

Notes: 1. Recommended Spares.

2. Materials of equivalent strength may be substituted at manufacturer's option.

Pressure Temperature Chart (in accordance with ASME B16.5, WCB)

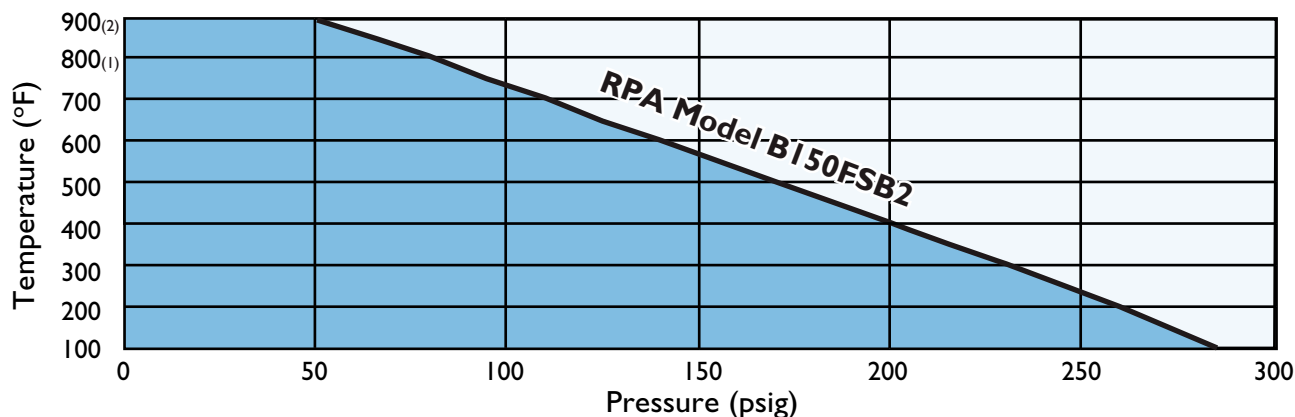

Notes: 1. Teflon and blueguard limited to 400°F maximum sustained operating temperature.

When operating RPA series B150F Style I strainers at higher temperatures please consult factory.

2. Upon prolonged exposure to temperatures above 800°F, the carbide phase of carbon steel may be converted to graphite.

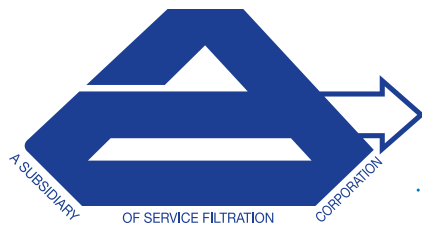

RPA Series BI50F Style I Cast Steel Flanged Basket Strainers

Standard Screens

Size range **Opening**

2 - 3" 0.045 in.

50mm - 80mm 1.2 mm

4" - 12" 0.125 in.

100mm - 300mm 3.2 mm

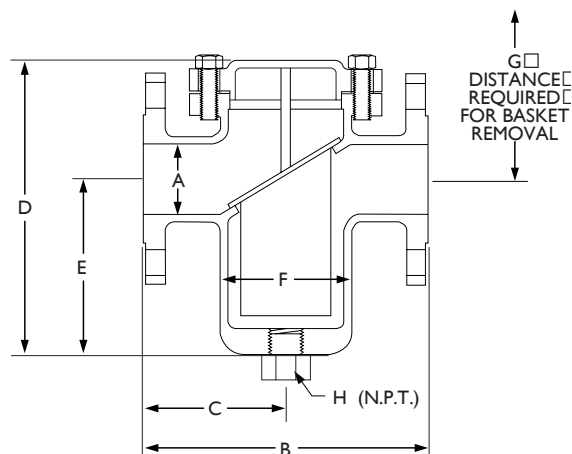

Dimensional Data (Class 150)

Size in (mm)	A in (mm)	B in (mm)	C in (mm)	D in (mm)	E in (mm)	F in (mm)	G in (mm)	H NPT in (mm)	Weight Cover	Lb./ (Kg.) Unit
2"	2.00	8.13	4.06	8.88	5.25	3.88	12.50	1	5	29
50	51	206	103	225	133	98	318	25	2.3	13
2 1/2"	2.50	8.75	4.38	9.75	5.50	4.00	14.00	1	7	33
65	64	222	111	248	140	102	356	25	3.2	15
3"	3.00	9.88	4.94	11.25	7.13	4.38	15.38	1	9	44
80	76	251	125	286	181	111	391	25	4.1	20
4"	4.00	11.50	5.75	15.38	9.50	5.25	21.25	1	13	67
100	102	292	146	391	241	133	540	25	5.9	30
5"	5.00	13.13	6.56	15.88	9.50	7.50	22.25	1	20	105
125	127	333	167	403	241	191	565	25	9.1	48
6"	6.00	14.88	7.44	16.00	9.50	7.50	22.50	1	26	120
150	152	378	189	406	241	191	572	25	12	54
8"	8.00	18.75	9.38	21.00	12.63	10.00	29.38	1	45	220
200	203	476	238	533	321	254	746	25	20	100
10"	10.00	20.13	10.06	24.75	14.50	11.63	35.00	1	70	292
250	254	511	256	629	368	295	889	25	32	132
12"	12.00	26.25	13.13	29.75	17.00	15.88	42.50	1 1/2	110	455
300	305	667	333	756	432	403	1080	40	50	206

Notes: 1. Vents are optional.

2. Dimension "B" is +/- 0.13".

3. Dimension "D" will change when Quick Opening covers are used.

4. Dimensions shown are subject to change. Consult factory for certified prints when required.

General

1. Quick opening cover features are shown on pages 11-12.

2. See pg. 14 for available perforations and screen materials.

3. Pressure drop information is shown on pg. 15.

4. See pg. 22 for ordering information.

5. Dimensions shown are subject to change.

Consult factory for certified prints when required.

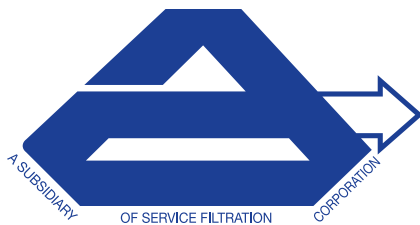

RPA Series B150F Style 2 Cast Steel Flanged Basket Strainers

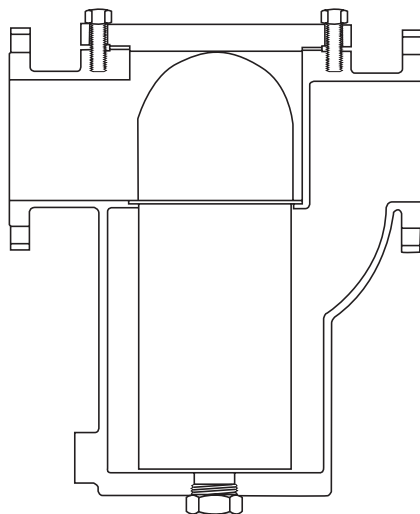

Design Features:

- Strainers are equipped with RF flanges in accordance with ASME B16.5.
- Strainer body meets ASME B16.5 and ASME B16.34.
- All strainers equipped with bolted cover flanges that utilize a flat gasket seal.
- Strainer cover flanges are in dimensional accordance with ASME B16.5.
- Over-the-top flow design complete with machined basket seats eliminates the possibility of dirty fluid by-pass.
- Standard basket construction is 304 SS perforated plate.
- Recommended minimum straining level is 40 microns.
- N.P.T. drain connection furnished with plug.
- Recommended for installation in horizontal pipelines.
- Generous screen area and properly proportioned outer annulus minimize pressure drop while maximizing time between cleanings.

Notes: 1. See page 11 for details of available quick opening covers.
2. See page 19 for basket strainer effective areas.

Parts List and Standard Materials

Part RPA Model	Carbon Steel B150FSB2	Stainless Steel B150FSSB2
Body	A216-WCB	A351-CF8M
Cover	A216-WCB	A351-CF8M
Screen ¹	304SS	304SS
Plug ²	A105	A182-316
Gasket ¹	Bolted Cover: 304SS Spiral Wound Quick Opening: See pg. 11	Bolted Cover: 304SS Spiral Wound Quick Opening: See pg. 11
Bolt/Stud ²	A193-B7	A193-B8-1
Nut ²	A194-2H	A194-8

Upper Pressure Limits (Non-Shock)

RPA Model	Body Material	M.A.W.P. psig (Bars)
B150FSB2	WCB	285 (19.65)
B150FSSB2	CF8M	275 (18.96)

Lower Temperature Limits

Body Material	Lower Limit ;F (;C)
WCB	-20 (-28.9)
CF8M	-20 (-28.9)

Notes: 1. Recommended Spares.
2. Materials of equivalent strength may be substituted at manufacturer's option.

Pressure Temperature Chart (in accordance with ASME B16.5, WCB)

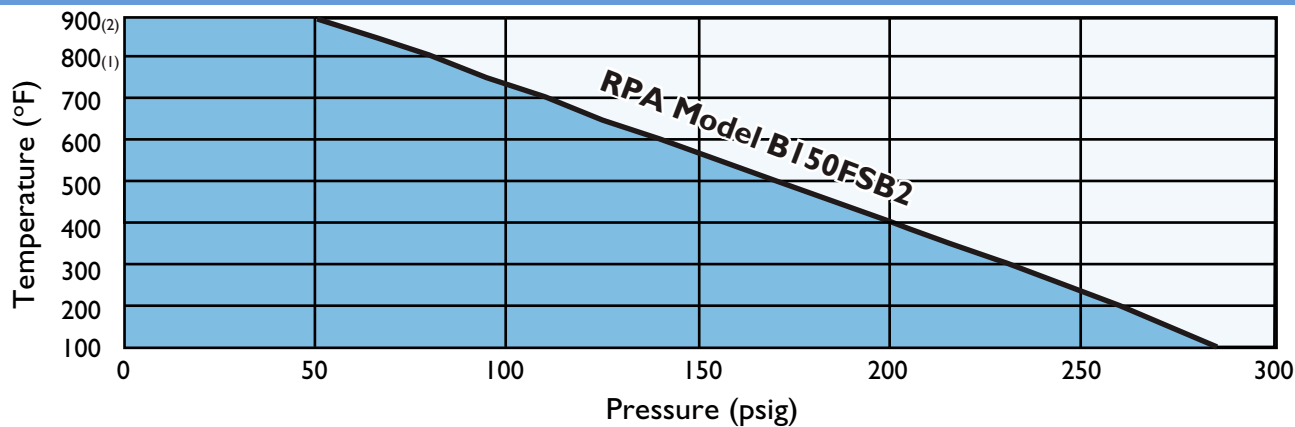

Notes: 1. Upon prolonged exposure to temperatures above 800°F, the carbide phase of carbon steel may be converted to graphite.
2. Graphite filled 304SS spiral wound gaskets limited to 900°F in an oxidizing atmosphere.
When operating strainers at higher temperatures please consult factory.

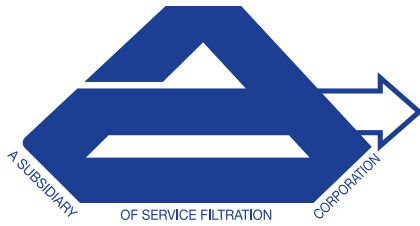

RPA Series BI50F Style 2 Cast Steel Flanged Basket Strainers

Standard Screens

Size range **Opening**

1 1/2" - 3" 0.045 in.

40mm - 80mm 1.2 mm

4" - 8" 0.125 in.

100mm - 200mm 3.2 mm

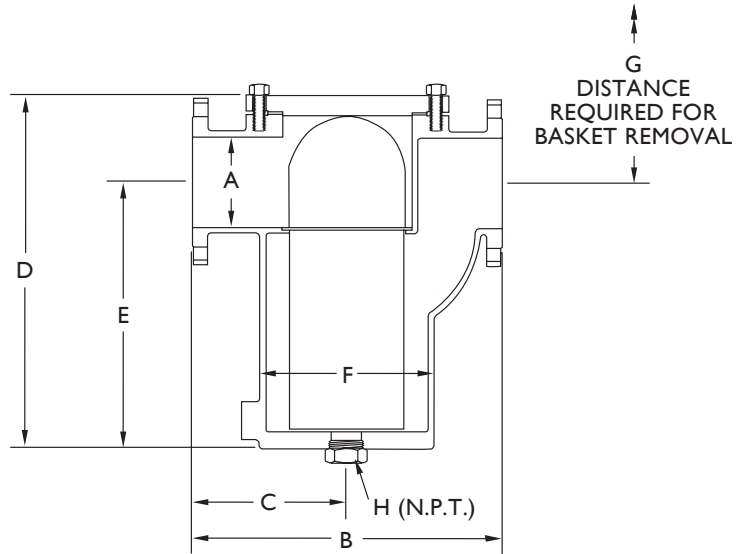

Dimensional Data (Class 150)

Size in (mm)	A in (mm)	B in (mm)	C in (mm)	D in (mm)	E in (mm)	F in (mm)	G in (mm)	H NPT in (mm)	Weight Lb./ Cover	(Kg.) Unit
1 1/2"	1.50	9.50	4.75	10.00	6.50	4.37	13.50	1/2	5	24
40	38	241	121	254	165	111	343	15	2.3	11
2"	2.00	10.50	5.25	11.63	7.63	4.87	15.63	3/4	7	46
50	51	267	133	295	194	124	397	20	3.2	21
3"	3.00	13.13	6.56	15.19	10.63	6.00	19.75	1	17	85
80	76	333	167	386	270	152	502	25	7.7	39
4"	4.00	17.25	8.38	15.75	10.75	7.38	20.75	2	20	120
100	102	438	213	400	273	187	527	50	9.1	54
6"	6.00	19.63	8.75	24.75	18.38	11.75	31.13	2	45	237
150	152	498	222	629	467	298	791	50	20	108
8"	8.00	27.00	13.00	34.63	27.00	13.88	42.25	2	70	372
200	203	686	330	879	686	352	1073	50	32	169

- Notes:**
1. Vents are optional.
 2. Dimension "B" is +/- 0.13".
 3. Dimension "D" will change when Quick Opening covers are used.
 4. All sizes come complete with a bottom drain. Side drains are optional.
 5. Dimensions shown are subject to change. Consult factory for certified prints when required.

General

1. Quick opening cover features are shown on pages 11-12.
2. See pg. 14 for available perforations and screen materials.
3. Pressure drop information is shown on pg. 15.
4. See pg. 22 for ordering information.
5. Dimensions shown are subject to change. Consult factory for certified prints when required.

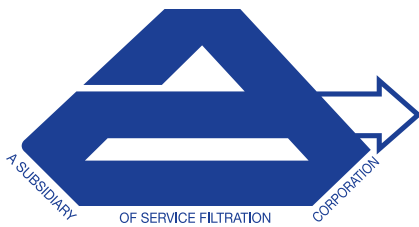

Quick Opening Covers

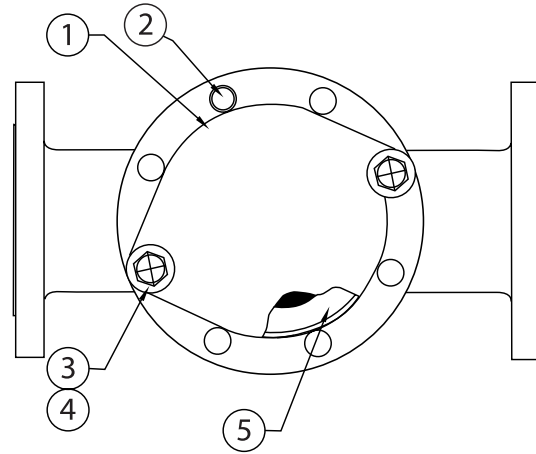
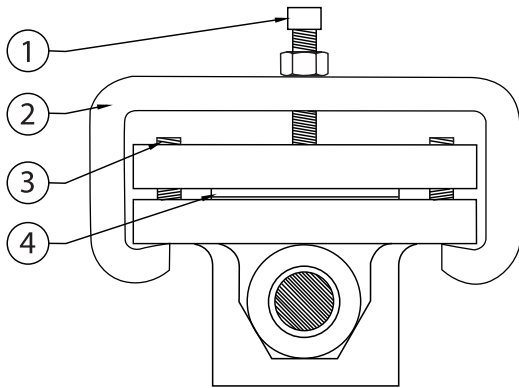

Cover Type C - Quick Opening C-Clamp

Design Features:

- Ideal for low pressure applications.
- Allows for extremely quick access to strainer basket.
- To be used on non-lethal liquid service only.

Availability	
Size Range	Available Body Material
1/2" - 12"	A126-B, B62, A216-WCB,
15mm - 300mm	A351-CF8M

Upper Pressure Limits (Non-Shock)	
M.A.W.P. psig (Bars)	Maximum Allowable Working Temp. °F (°C)
50 (3.44)	100 (37.8)

Parts List and Standard Materials		
Item	Part	Specification
1	Clamp Bolt ²	A449 Grade 5
2	Clamp	A516-70 Carbon Steel
3	Anti-Rotating Stud ²	A307-B
4	Gasket ¹	See below

Notes: 1. Recommended Spares.
2. Materials of equivalent strength may be substituted at manufacturer's option.

Gasket Materials Utilized	
Size Range	Gasket Type
1/2" - 6"	Flat Rubber
15mm - 150mm	(Non-asbestos)
8" - 12"	Buna-N O-Ring
200mm - 300mm	(Groove in Cover)

CAUTION:
This type of closure does not meet the requirements of Section UG-35.2 of ASME Section VIII, Div.1. Use caution when using this type of device.

Cover Type R - Rotating Cover

Design Features:

- Used for medium pressure applications.
- Easy maintenance and quick-opening.

Availability	
Size Range	Available Body Material
1/2" - 3"	A126-B, B62, A216-WCB,
15mm - 80mm	A351-CF8M

Upper Pressure Limits (Non-Shock)		
Strainer Body Material	M.A.W.P. psig (Bars)	Maximum Allowable Working Temp. °F (°C)
A126-B	200 (13.79)	100 (37.8)
B62	225 (15.51)	100 (37.8)
A216-WCB	285 (19.65)	100 (37.8)
A351-CF8M	275 (18.96)	100 (37.8)

Upper Pressure Limits (Non-Shock)			
Item	Part	Strainer Body A126-B, WCB	Material B62, CF8M
1	Cover	A516-70	A240-304
2	Positioning Stud ²	Steel	Stainless Steel
3	Cover Stud ²	A193-B7	A193-B8-1
4	Cover Nut ^{2,3}	A194-2H	A194-8
5	Gasket ^{1,4}	Flat Rubber	Flat EPDM

Notes: 1. Recommended Spares.
2. Materials of equivalent strength may be substituted at manufacturer's option.
3. Quick release knobs are available. Contact factory.
4. Other gasket types are available. Contact factory.

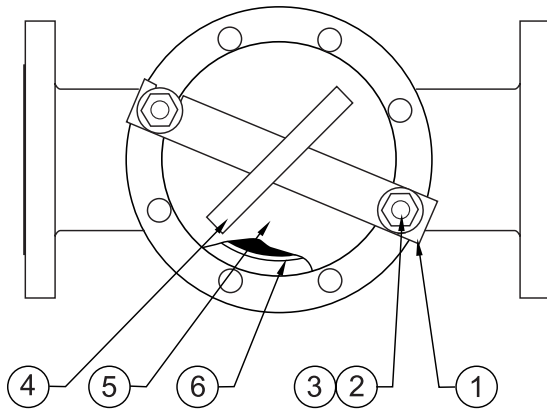
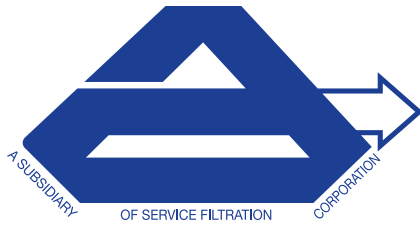

Cover Type Y - Swing Yoke

Design Features:

- Used for medium pressure applications.
- Easy maintenance and quick-opening.

Availability	
Size Range	Available Body Material
3" - 8"	A126-B, B62, A216-WCB,
80mm - 200mm	A351-CF8M

Upper Pressure Limits (Non-Shock)		
Strainer Body Material	M.A.W.P. psig (Bars)	Maximum Allowable Working Temp. °F (°C)
A126-B	125 (8.62)	100 (37.8)
B62	125 (8.62)	100 (37.8)
A216-WCB	150 (10.34)	100 (37.8)
A351-CF8M	150 (10.34)	100 (37.8)

Notes: 1. Sizes 6" and 8" rated for 100 psig maximum.

Parts List and Standard Materials			
Item	Part	Strainer Body Material A126-B, WCB	B62, CF8M
1	Clamp	A516-70	A240-304
2	Body Bolt ²	A193-B7	A193-B8-1
3	Body Nut ²	A194-2H	A194-8
4	Clamp Bolt ²	A449 Grade 5	18-8 Stainless Steel
5	Cover	A126-B, WCB	B62, CF8M
6	Gasket ^{1,3,4}	Buna-N O-Ring	Viton O-Ring

- Notes:** 1. Recommended Spares.
 2. Materials of equivalent strength may be substituted at manufacturer's option.
 3. Other O-Ring materials are available. Contact factory.
 4. O-Ring groove is located in cover.

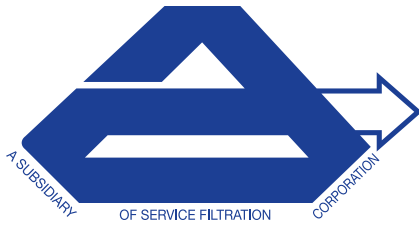

Replacement Baskets

Design Features:

RPA design's and manufactures baskets for all makes of basket and duplex strainers. The range of materials and size of units is unlimited.

RPA is able to provide baskets manufactured from:

- Perforated Plate
- Mesh or Mesh/Perf. combination
- Wedge Wire
- Electron Beam Small Hole Perforated Plate

Using the above processes or combination thereof, RPA can provide screens and baskets suitable for a wide range of applications.

Screen/Basket Checklist

Kindly photocopy this page and fill out the pertinent information.

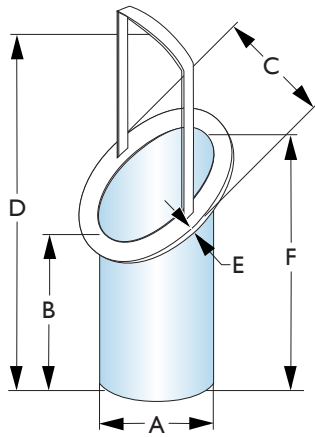

**BASKET STRAINER
STYLE "1"**

Performance Requirements

Description	Customers Requirement
Required Level of Filtration	_____
Material of Construction	_____
Minimum Specified Burst Pressure	_____
Flow Direction	_____
Other	_____

Dimensional Requirements

Description	Customers Requirement
Basket Style	(1 or 2)
Basket Outer Diameter	A
Basket Height	B
Ring OD	C
Overall Height	D
Ring Thickness	E
Basket Long Height	F

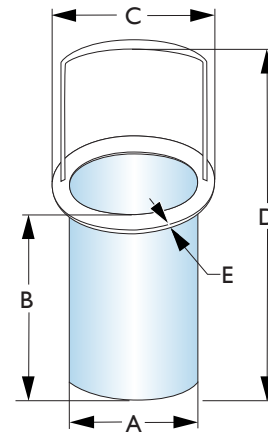

**BASKET STRAINER
STYLE "2"**

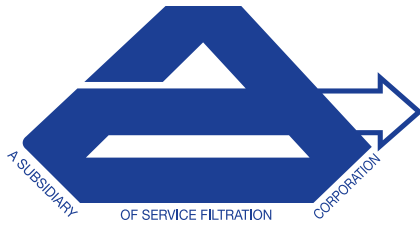

Engineering Data

Screen Openings for Basket Strainers

Factors To Consider

Purpose

If the basket strainer is being used for protection rather than direct filtration, RPA's standard screens will suffice in most applications.

Service

With services that require extremely sturdy screens, such as high pressure/ temperature applications or services with high viscosities, RPA recommends that perforated screens without mesh liners be used. If mesh is required to obtain a certain level of filtration, then RPA recommends a trapped perf./mesh/perf. combination.

Filtration Level

When choosing a perf. or a mesh/perf. combination attention should be given to ensure overstraining does not occur. As a general rule the specified level of filtration should be no smaller than half the size of the particle to be removed. If too fine a filtration is specified the pressure drop through the strainer will increase very rapidly, possibly causing damage to the basket.

Screen Types/Dimensions

1/4" Dia. - 40% O.A.	3/16" Dia. - 50% O.A.	5/32" Dia. - 58% O.A.	1/8" Dia. - 40% O.A.	3/32" Dia. - 39% O.A.	1/16" Dia. - 37% O.A.	3/64" Dia. - 36% O.A.	1/4" Dia. - 40% O.A.	0.027" Dia. - 23% O.A.	20 Mesh - 49% O.A. 0.035" Openings	30 Mesh - 45% O.A. 0.022" Openings	40 Mesh - 41% O.A. 0.016" Openings	60 Mesh - 38% O.A. 0.010" Openings	80 Mesh - 36% O.A. 0.008" Openings	100 Mesh - 30% O.A. 0.006" Openings

- Notes:**
1. Screen openings other than those shown above are readily available. RPA inventories various mesh sizes as fine as 5 micron and perforated plate as coarse as 1/2" Dia.
 2. Screens are available in a wide range of materials. RPA inventories various screen material in carbon steel, stainless steel (304, 316), alloy 20, monel 400, hastalloy C and titanium grade 2.
 3. Custom manufactured screens are available upon request. Please consult factory.

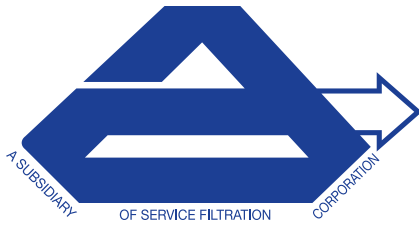

Engineering Data Basket Strainer Pressure Drop-Liquids

Threaded Basket Strainer Pressure Drop - Liquids (Sizes 1/2 - 1 1/2)

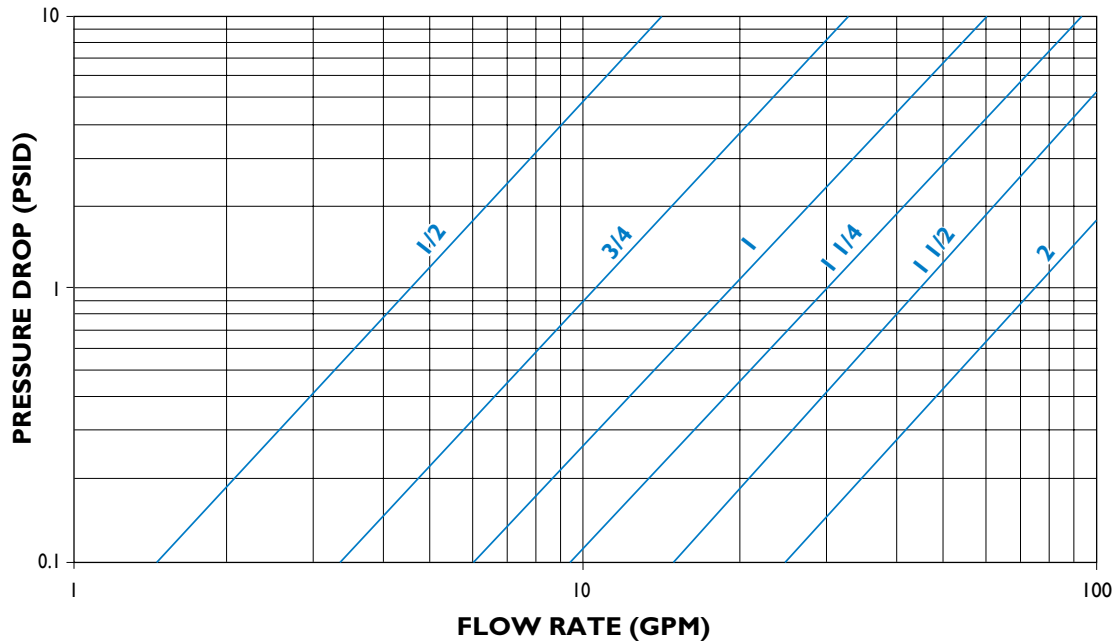

FIGURE 1

Flanged Basket Strainer Pressure Drop - Liquids (Sizes 2 - 24)

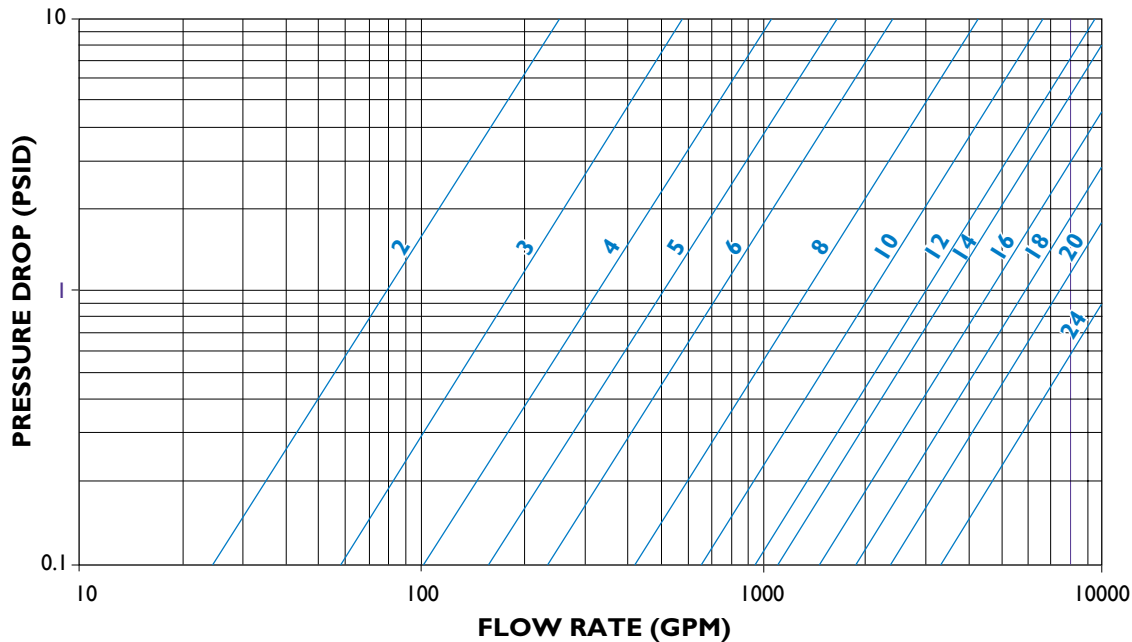
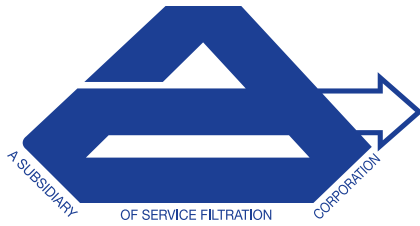

FIGURE 2

Notes: 1. Pressure drop curves are based on water flow with standard screens.

See page 16 for correction factors to be used with other fluids and/or screen openings.

2. For Style 1 basket strainers multiply value obtained in figure 2 by 1.15 to obtain clean pressure drop.



Engineering Data Screen Correction Factor Chart

For Non-Standard and Mesh Lined Screens

*Multiply values obtained from figure 1 thru 2 by the appropriate values shown below

Chart #1

Size Range	SCREEN OPENINGS							
	Perforated Plate % Screen Material Open Area					Mesh lined standard screens % Screen Material Open Area		
	60%	50%	40%	30%	20%	50%	40%	30%
1/4" - 1 1/2"	0.45	0.55	0.7	1	1.15	1.05	1.05	1.2
2" - 16"	0.65	0.8	1	1.4	2.15	1.05	1.05	1.2

- Notes:**
1. See page 14 for % Open Area's of RPA inventoried perforated plate.
 2. Standard screens for sizes 1/4" to 1-1/2" is approximately a 30% open area screen media.
 3. Standard screens for sizes 2" and larger is approximately a 40% open area screen media.

Example:

Strainer Size: 2" Style 2
Filtration: 100 Mesh lined 1/8" perf.
Flow rate: 70 GPM
Service: Water

- A) Using figure 1 the pressure drop is determined to be 0.9 psig with RPA's standard screen.
- B) Looking at page 14 we find that the % Open area of 100 mesh is 30%.
- C) Using chart 1 we read the correction factor to be 1.2 for 100 mesh lined 1/8" perf.
- D) Total pressure drop equals $0.9 \times 1.2 = 1.08$ psig clean.

Viscosity and Density Correction Factor Chart

* For use see instructions below.

Chart #3

Size Range	Component factor (CF)	Chart #2		Chart #3			
		Viscosity Cp	Body Loss Factor (BF)	Perf alone (PF)	Screen Loss Factor 20 mesh lined (MF)	Screen Loss Factor 30 & 40 mesh lined (MF)	Screen Loss Factor 60 to 300 mesh lined (MF)
1/4" - 1 1/2"	0.25	10	1	1.15	1.3	1.4	1.5
2" - 16"	0.35	25	1.2	1.25	2	2.2	2.5
		100	1.6	1.4	3	4	6.5
		200	2.2	1.5	4.5	7	11.5
		500	4.4	1.6	10	15	25
		1000	8	1.7	15	30	50
		2000	15.2	1.9	30	60	100

How to Use:

- 1) Using figures 1 or 2 determine the pressure drop (P1) through the strainer with water flow and standard screens.
- 2) If non-standard screens (i.e. 40 mesh, etc.) are being used apply factors in chart #1 to determine corrected pressure drop (P2).
- 3) Multiply P1 or P2 (is used) by the specific gravity of the fluid actually flowing through the strainer to get P3.
- 4) Using chart #2 multiply P3 by the appropriate Component Factor (CF) to get P4.
- 5) Let $P5 = P3 - P4$.
- 6) Multiply P4 by the appropriate Body Loss Factor (BF) in chart #3 to get P6.
- 7) Multiply P5 by the appropriate Screen Loss factor (PF or MF) in chart #3 to get P7.
- 8) Total pressure drop $P8 = P6 + P7$.

Example:

Strainer Size: 2" Style 2
Filtration: 100 mesh lined 1/8" perf.
Flow rate: 70 GPM
Specific Gravity: 1
Viscosity: 100 cP

- A) As shown in the above example, the corrected pressure drop (P2) = 1.08 psig
- B) Since S.G. = 1, $P3 = P2 = 1.08$ psig
- C) Using chart #2 $P4 = 0.35 \times P3 = 0.38$ psig
- D) $P5 = 1.08 - 0.38 = 0.70$ psig
- E) Using chart #3 $P6 = 0.38 \times 1.6 = 0.61$ psig
- F) Again using chart #3 $P7 = 0.70 \times 6.5 = 4.55$ psig
- G) Total pressure drop $P8 = 0.61 + 4.55 = 5.16$ psig

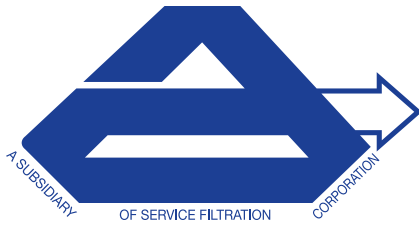

Engineering Data Correction Factors For Clogged Screens

* Multiply values obtained from figures 1 thru 2 and charts #1, #2 and #3 (if used) by the appropriate values shown below

% Clogged	Ratio of Free Screen Area to Pipe Area						Chart #4
	10:1	8:1	6:1	4:1	3:1	2:1	
10%	-	-	-	-	-	-	3.15
20%	-	-	-	-	-	1.15	3.9
30%	-	-	-	-	-	1.4	5
40%	-	-	-	-	-	1.8	6.65
50%	-	-	-	-	1.25	2.5	9.45
60%	-	-	-	1.15	1.8	3.7	14.5
70%	-	-	-	1.75	2.95	6.4	26
80%	-	1.1	1.75	3.6	6.25	14	58
90%	2.3	3.45	6	13.5	24	55	-

Notes: 1. See page 14 for the ratio of free area to pipe area for RPA Basket Strainers equipped with standard screens.
2. For screens other than RPA's standard use the following formula to calculate the ratio free area to pipe area:

$$R = \frac{A_g \times OA}{100A_p}$$

where; R = Ratio free area to pipe area
 A_g = Gross screen area, sq. in. (See page 19)
 OA = Open area of screen media, % (See page 14, i.e. $1/16$ " perf. = 37%)
 A_p = Nominal area of pipe fitting, sq. in. (See page 19)

Example #1

Strainer Size: 10"
RPA Series: B150F (Style 2)
Filtration: $1/8$ " perf.
Flow rate: 3000 GPM
Service: Water
% Clogged: 60%

- A)** Using figure #1 the pressure drop is determined to be 2.0 psig with RPA's standard screen.
B) Looking at page 19 the ratio of free area to pipe area for a 10" RPA series B150F (Style 1) strainer is equal to 2.1:1 (2:1 approx.).
C) Using chart #4 we read the correction factor to be 3.7 at 60% clogged.
D) Total pressure drop equals $2.0 \times 3.7 = 7.4$ psig when 60% clogged.

Example #2

Strainer Size: 12"
RPA Series: B150F (Style 2)
Filtration: $3/16$ " perf.
Flow rate: 3000 GPM
Service: Water
% Clogged: 70%

- A)** Using figure #1 the pressure drop is determined to be 1.0 psig with RPA's standard screen.
B) Looking at page 14 we find that the % Open area (OA) of $3/16$ " perf. is 50%.
C) Using chart #1 we read the correction factor to be 0.8 for $3/16$ " perf.
D) Total clean pressure drop equals $1.0 \times 0.8 = 0.8$ psig.
E) Since a non-standard screen is being used we must calculate the ratio free area to pipe area using the above formula.
F) Looking at page 27 we find $AG = 693.85$ in², $A_p = 113.10$ in².
G) The ratio free area to pipe area is calculated as 3.07:1. (3:1 approx.)
H) Using chart #4 we read the correction factor to be 2.95 at 70% clogged.
I) Total pressure drop equals $0.8 \times 2.95 = 2.36$ psig when 70% clogged.

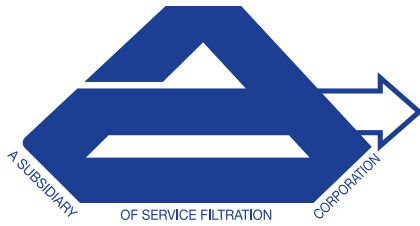

Engineering Data Basket Strainer Basket Burst Pressure

FIGURE 3

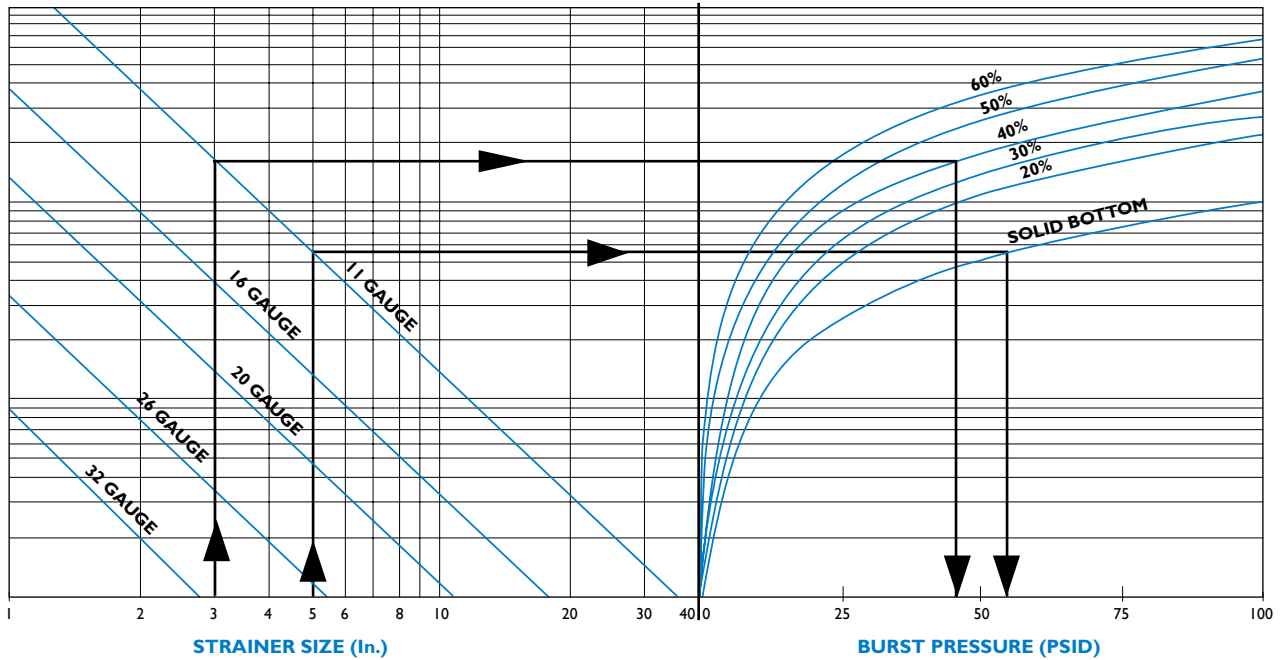

- Notes:**
1. The above chart is to be used for strainers manufactured from perforated plate and is based on the formula below
 2. As standard, RPA supplies baskets with perforated bottoms.
 3. The above chart is based on RPA's standard dimensions. Higher burst pressure ratings are available. Please contact factory.
 4. The above chart is based on a screen material of stainless steel. No safety factor is incorporated. It is the responsibility of the user to determine an acceptable safety factor.
 5. See page 14 for % Open Area's of RPA's inventoried perforated plate.

$$t = d \sqrt{\frac{0.3P}{S}}$$

SOURCE: ASME Section VIII, Div. I., UG-34.

- t = Thickness of perforated plate, in.
- d = Basket Diameter, in.
- P = Burst Pressure, psi
- S = Reduced allowable stress, psi

Example: #1

Strainer Size: 5"
Basket Type: Perforated screen with 11 gauge solid flat bottom
Screen Material Open Area: 20% - 60%

- Locate Strainer size.
- Follow vertical line to solid thickness.
- Follow horizontal line to solid bottom curve.
- Follow vertical line downwards to read burst pressure.
- Burst pressure equals 55 psig.

Example: #2

Strainer Size: 3"
Basket Type: 11 gauge perforated screen with 11 gauge perforated flat bottom
Screen Material Open Area: 40%

- Locate Strainer size.
- Follow vertical line to gauge thickness.
- Follow horizontal line to 40% open area curve.
- Follow vertical line downwards to read burst pressure.
- Burst pressure equals 45 psig.

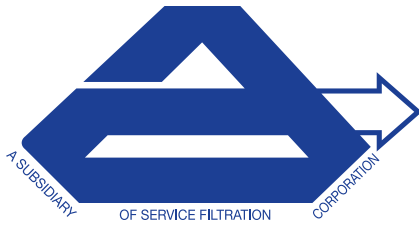

Engineering Data Basket Strainer Effective Areas

RPA Series	Pipe Size (In.)	Opening (in.)	Sch. 40 / Std. Pipe Area (Sq. In.)	Screen Area (Sq. In.)	Free Area (Sq. In.)	Free Area to Pipe Area
B300 (Style #2)	1/2	0.032	0.30	14.73	4.12	13.6
B300 (Style #2)	3/4	0.032	0.53	23.01	6.44	12.1
B300 (Style #2)	1	0.032	0.86	23.01	6.44	7.5
B300 (Style #2)	1 1/4	0.032	1.50	47.80	13.38	8.9
B300 (Style #2)	1 1/2	0.032	2.04	47.80	13.38	6.6
B300 (Style #2)	2	0.045	3.36	58.32	21.00	6.3
B125FIB (Style #1)	2	0.045	3.36	29.27	10.54	3.1
B125FIB (Style #1)	2 1/2	0.045	4.79	45.11	16.24	3.4
B125FIB (Style #1)	3	0.045	7.39	78.53	28.27	3.8
B125FIB (Style #1)	4	0.125	12.73	106.51	42.60	3.3
B125FIB (Style #1)	5	0.125	20.01	139.27	55.71	2.8
B125FIB (Style #1)	6	0.125	28.89	176.16	70.46	2.4
B125FIB (Style #1)	8	0.125	50.03	300.37	120.15	2.4
B125FIB (Style #1)	10	0.125	78.85	446.39	178.56	2.3
B125FIB (Style #1)	12	0.125	113.10	654.83	261.93	2.3
B125FIB (Style #1)	14	0.125	137.89	885.34	354.14	2.6
B125FIB (Style #1)	16	0.125	182.65	1437.23	574.89	3.1
B125FIB (Style #1)	18	0.125	233.71	1437.23	574.89	2.5
B125FIB (Style #1)	20	0.125	291.04	1916.37	766.55	2.6
B150FBB (Style #1)	2	0.045	3.36	29.27	10.54	3.1
B150FBB (Style #1)	2 1/2	0.045	4.79	45.11	16.24	3.4
B150FBB (Style #1)	3	0.045	7.39	78.53	28.27	3.8
B150FBB (Style #1)	4	0.125	12.73	106.51	42.60	3.3
B150FBB (Style #1)	5	0.125	20.01	139.27	55.71	2.8
B150FBB (Style #1)	6	0.125	28.89	176.16	70.46	2.4
B150FSB (Style #1)	2	0.045	3.36	35.20	12.67	3.8
B150FSB (Style #1)	3	0.045	7.39	57.86	20.83	2.8
B150FSB (Style #1)	4	0.125	12.73	116.03	46.41	3.6
B150FSB (Style #1)	6	0.125	28.89	167.33	66.93	2.3
B150FSB (Style #1)	8	0.125	50.03	303.77	121.51	2.4
B150FSB (Style #1)	10	0.125	78.85	409.43	163.77	2.1
B150FSB (Style #1)	12	0.125	113.10	693.85	277.54	2.5
B150FSB (Style #2)	1 1/2	0.045	2.04	30.74	11.07	5.4
B150FSB (Style #2)	2	0.045	3.36	44.07	15.87	4.7
B150FSB (Style #2)	3	0.045	7.39	105.29	37.90	5.1
B150FSB (Style #2)	4	0.125	12.73	143.21	57.29	4.5
B150FSB (Style #2)	6	0.125	28.89	364.56	145.82	5.0
B150FSB (Style #2)	8	0.125	50.03	666.56	266.62	5.3

- Notes:**
1. Values shown are approximate. Contact factory for exact ratios.
 2. Values shown are for strainers with standard screens.
 3. The ratio free area to pipe area may be increased by changing perf. stagger or by using heavy wire mesh.

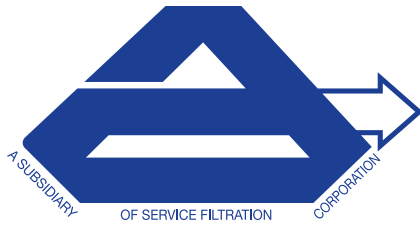

Check List and Suggested Specifications For RP Adams Inc.

Strainer Check List: When selecting a strainer, please take the factors listed below into account. This will assist us when recommending a strainer to suit your specific requirements. Please photocopy this page and fill out the pertinent information.

1. Fluid to be strained _____
2. Flow rate _____
3. Density of fluid _____
4. Viscosity of fluid _____
5. Fluid working pressure _____
Maximum pressure _____
6. Fluid working temp. _____
Maximum temp. _____
7. Preferred material of strainer construction _____

8. Present pipeline size & material _____
9. Nature of solids to be strained out _____
10. Size of solids to be strained out _____
Size of mesh or perf. req. _____
11. Clearance Limitation Above _____ Below _____
Left side facing inlet _____ Right side facing inlet _____
12. Maximum pressure drop with clean screen _____
13. Expected cleaning frequency _____
14. Any other information deemed relevant _____

Suggested Specifications

The strainer shall be a basket strainer and have _____ (size) inlet/outlet connections. The end connections shall be (flanged, threaded etc.) and the body shall be complete with a _____ (bolted, quick-opening, etc.) cover assembly. The strainer shall be suitable for _____ PSIG operating pressure at _____ °F operating temperature. The body shall be constructed of _____ (body material) while the screen shall be constructed of _____ (basket or screen material). A mesh lining of _____ (size of mesh) is required, allowing a maximum pressure drop of _____ psig. The strainer shall be equipped with a _____ (gasket material) gasket and the strainer screen shall be able to withstand _____ psig differential pressure without any deformation.

Strainers shall be RPA Model # _____ or approved equivalent.

Name _____
Company _____
Address _____
City/Town _____
State _____ Zip Code _____
Telephone (_____) _____
Fax (_____) _____

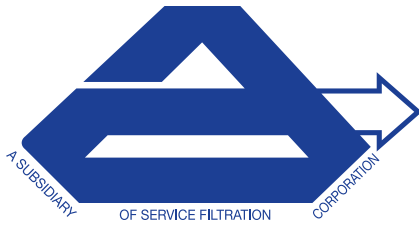

Installation and Maintenance Instructions for RPA Basket Strainers

1.0 Strainer Installation Instructions

- A. Ensure all machined surfaces are free of defects and that the inside of the strainer is free of foreign objects.
- B. For horizontal pipelines, the strainer should be installed so that the drain connection is pointed downwards.
- C. For flanged end strainers, the flange bolting should be tightened gradually in a back and forth clockwise motion. Threaded end strainers should use an appropriate sealant.
- D. Once installed, increase line pressure gradually and check for leakage around joints.
- E. If the strainer is supplied with a start-up screen, monitor pressure drop carefully.

2.0 Basket Removal Instructions

- A. Drain piping.
- B. Vent line to relieve pressure.
- C. Loosen cover and open to access basket.
- D. Remove, clean and replace basket in original position. (Note: In some instances, a high pressure water jet or steam may be required for effective cleaning).
- E. Inspect cover gasket for damage. If necessary, replace. (Note: If spiral wound gaskets have been used, they must be replaced and can not be used again).
- F. Tighten cover. The strainer is ready for line start-up.

CAUTION SHOULD BE TAKEN DUE TO POSSIBLE EMISSION OF PROCESS MATERIAL FROM PIPING. ALWAYS ENSURE NO LINE PRESSURE EXISTS WHEN OPENING COVER.

3.0 Maintenance Instructions

For maximum efficiency, determine the length of time it takes for the pressure drop to double that in the clean condition. Once the pressure drop reaches an unacceptable value, shut down line and follow the "Basket Removal Instructions" above.

A pressure gauge installed before and after the strainer in-line will indicate pressure loss due to clogging and may be used to determine when cleaning is required.

4.0 Trouble Shooting Guides and Diagnostic Techniques

- A. After pressurizing, inspect cover and other joints for leakage. Gasket replacement or cover tightening is necessary if leakage occurs.
- B. If the required filtration is not taking place, ensure the basket is installed in the correct position, that being flush to the basket seating surfaces.

5.0 Limited Warranty

All products are warranted to be free of defects in material and workmanship for a period of one year from the date of shipment, subject to the limitations below: If the purchaser believes a product defective, the purchaser shall:

- (a) Notify the manufacturer, state the alleged defect and request permission to return the product.
- (b) If permission is given, return the product with transportation prepaid. If the product is accepted for return and found to be defective, the manufacturer will, at its discretion, either repair or replace the product, f.o.b. factory, within 60 days of receipt, or refund the purchase price.

Other than to repair, replace or refund described above, the purchaser agrees that the manufacturer shall not be liable for any losses, costs, expenses or damages of any kind arising out of the product, its use, installation or replacement, labeling, instructions, information or technical data of any kind, description of product use, sample or model, warnings or lack of foregoing. No other warranties, written or oral, expressed or implied, including the warranties of fitness for a particular purpose and merchantability, are made or authorized. No affirmation of fact, promise, description of product use or sample or model shall create any warranty from the manufacturer, unless signed by the president. These products are not manufactured, sold or intended for personal, family or household purposes.

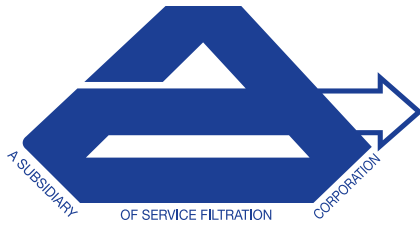

How To Order

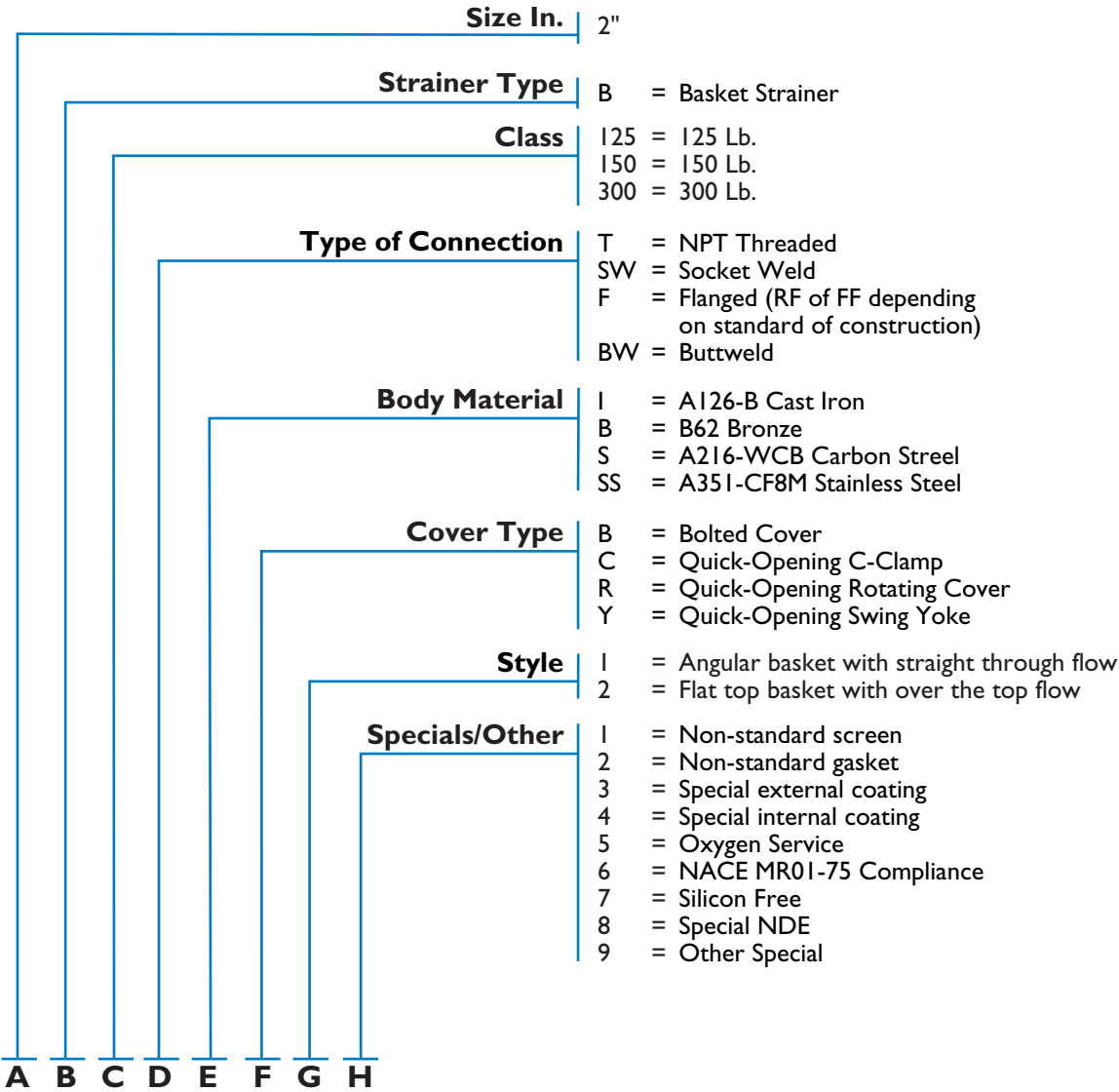

Value Added Flow Control Products
For All Industries.



R.P. ADAMS

A SUBSIDIARY OF SERVICE FILTRATION CORPORATION

R. P. Adams Company, Inc.

P.O. Box 963 • Buffalo, NY, 14240

Toll Free: 800-896-8869 • Telephone: 716-877-2608

Fax: 716-877-9385

E-mail: info@rpadams.com