

ADAMS TYPE FL-1 FIBERGLASS LINED FILTERS

DIMENSIONS

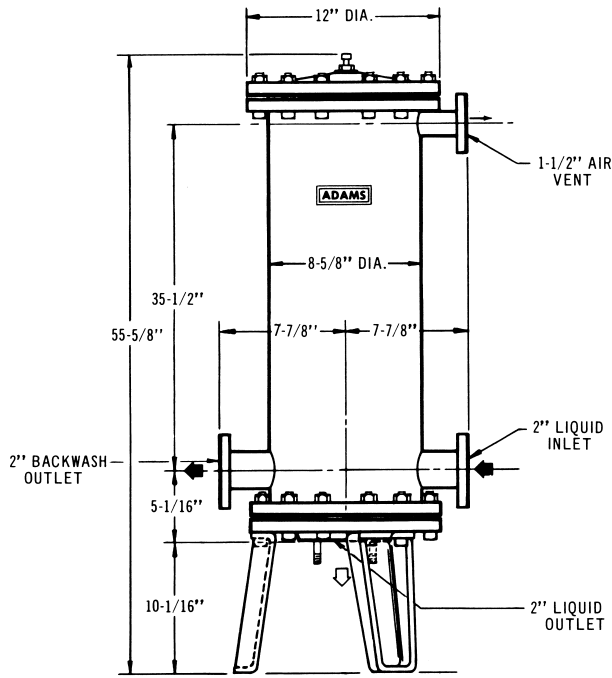

150 Lb. A.S.A. Drilled Flanges. Dimensions vary slightly due to tolerances required for lining.

PARTS LIST

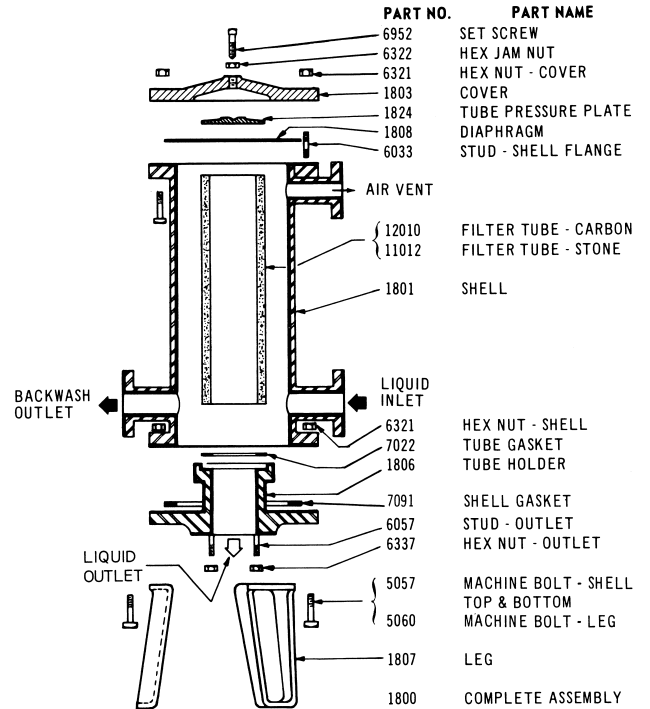

ADAMS TYPE RL-1 RUBBER LINED FILTERS

DIMENSIONS

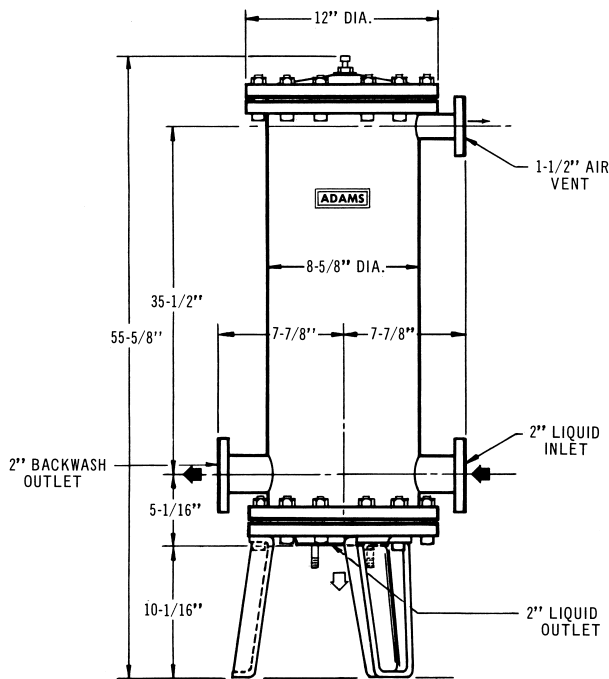

150 Lb. A.S.A. Drilled Flanges. Dimensions vary slightly due to tolerances required for lining.

PARTS LIST

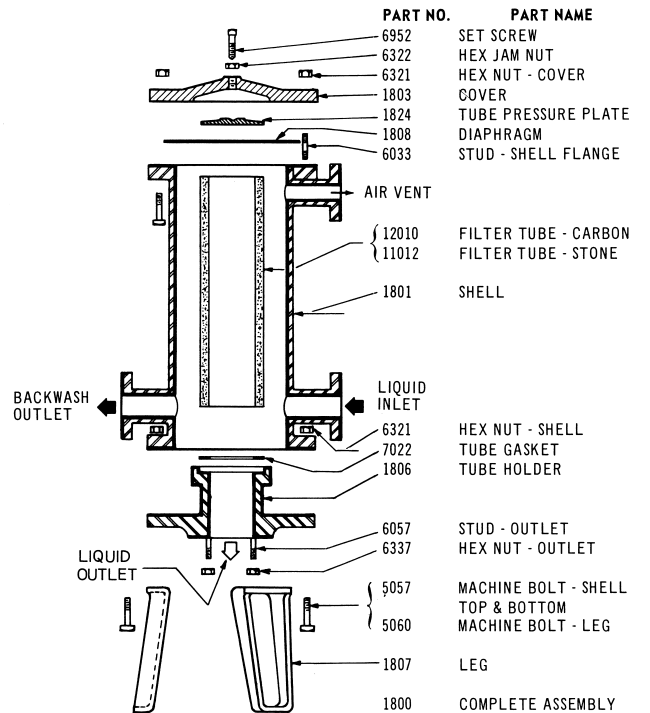

THE CERTIFIED DATE OF THIS DRAWING SUPERSEDES ALL PRIOR DRAWINGS

CUSTOMER ADDRESS
 CUSTOMER'S ORDER NO. DATE SIZE
 OUR NO. JOB NO. CERTIFIED DATE
 APPROVED BY DATE

R. P. ADAMS COMPANY, INC.
 BUFFALO, NEW YORK 14240

SP-35490

DATE: 3-1-74