

INSTALLATION AND MAINTENANCE MANUAL
FOR THE
GP PORO-CARBON STEAM FILTER



R. P. Adams
P.O. Box 963
Buffalo, NY, 14240 USA
Toll Free: 800-896-8869
Telephone: 716-877-2608
Fax: 716-877-9385
E-mail: info@rpadams.com
Website: www.rpadams.com

1) GENERAL

- 1.1 The Adams GP Series steam filter can be used for continuous or intermittent service and is designed to provide long life if properly installed, operated and maintained. The GP filter uses the exclusive Adams Poro-Carbon tube element that provides superior durability and performance.

2) INSTALLATION

- 2.1 Purge the pipeline before installing the filter to rid the system of particles that may prematurely plug the Poro-Carbon filter element.
- 2.2 Always install the Adams GP Series Steam Filter close to the point of use and in a vertical position. Make sure there is enough clearance above the filter for maintenance and removal of the tube element. Also provide adequate clearance below the filter for the installation of a steam condensate trap.
- 2.3 A suitable automatic trap, which is available from the R. P. Adams, to drain condensate is recommended since the filter is not designed to store condensate. The Poro-Carbon tube element is subject to erosion if condensate is not continually removed from the filter. The filter drain trap connection is $\frac{1}{4}$ " FPT for GP sizes $\frac{1}{2}$ " to 3" and $\frac{1}{2}$ " FPT for GP sizes 4" to 6".

☑ Caution: Do not operate the filter beyond the design pressure and temperature capabilities stated on the nameplate of the unit.

3) OPERATION

- 3.1 The Adams GP Series Steam Filter provides continuous filtration by removing 95% of particles two micron or larger. Separation is performed in a two-step operation. Steam is directed in a tangential flow around the element and against the inside wall, providing separation of larger particles and droplets. Contaminants are captured in patented vertical slots located on the filter's sidewalls. A steam flow interrupter at the bottom of the unit improves draining efficiency and reduces condensate re-entrainment from liquid collected before the drain. The steam is then diffused through the Poro-Carbon tube to achieve maximum filtration.

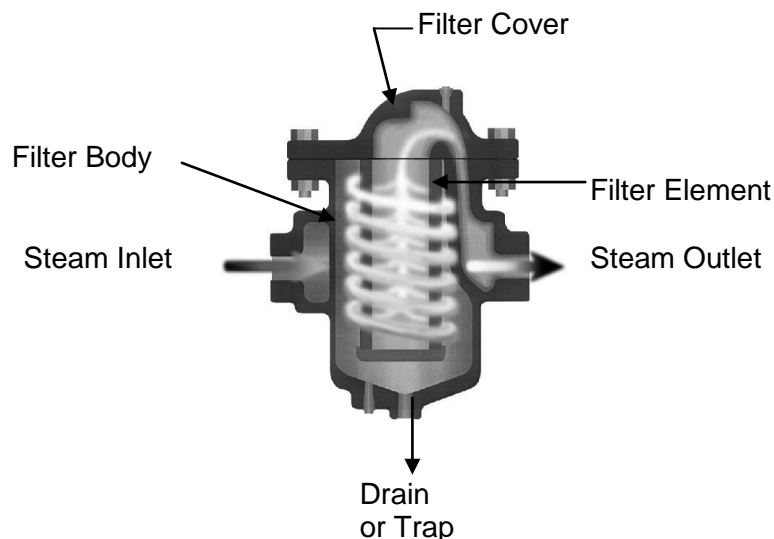

4) MAINTENANCE AND CLEANING

- 4.1 The filter tube is accessible for inspection and cleaning by removing the bolts that secure the cover to the filter body. The Poro-Carbon filter element is attached to the filter cover in a single assembly that permits easy removal and cleaning without contaminating the filtered side.
 - Caution: Make sure the steam pressure is turned off before performing any inspection or maintenance.**
- 4.2 The Poro-Carbon tube element should be inspected and cleaned or replaced periodically. Generally the filter element should be inspected, cleaned or replaced about once a year or when pressure differential across the unit so dictates.
- 4.3 If excessive iron oxide (rust) is present, soak the tube in a 2½% solution of muriatic acid (hydrochloric) four (4) to six (6) hours and rinse well in clean water. Poro-Carbon tube elements may also be cleaned by mounting the element in a lathe and cutting approximately one thirty-second of an inch off the outside diameter of the element.
- 4.4 Clean the inside of the filter housing to remove any contamination that may foul the automatic trap. When reassembling, be sure to use the tube element gaskets to seal ends of all tubes. The top cover gasket should also be aligned properly on the internal cast partition for Models ½" GP-22, ¾" GP-31, 1" GP-47, 1½" GP-99, 2" GP-132 and 3" GP-283.

5) REPLACEMENT PARTS

- 5.1 When replacing or reinstalling the Poro-Carbon tube element, be sure to also replace the filter tube element gaskets and filter cover gaskets. Parts can be obtained through your local R. P. Adams sales representative or through our sales department in Buffalo, NY.
- 5.2 To keep downtime to a minimum, it is beneficial to have a spare tube element on hand for quick change out. The dirty tube element can be cleaned as time permits.
- 5.3 When ordering parts, please be sure to have the GP model and design pressure available. This information is located on the nameplate of the unit.
- 5.4 An illustrated parts list for each GP Steam Filter is given in section 7 of this manual.

6) TROUBLESHOOTING

- 6.1 Filter has a pressure drop greater than 5 PSI.
 - a) High pressure drop may be caused by a dirty filter element. Inspect the filter tube element to determine if it requires cleaning.
 - b) If the tube element is clean, then it is possible that there is more steam being put through the filter than proper for its size. Contact your local Adams R. P. Adams sales representative for further assistance.
- 6.2 Particles are being found downstream from the filter.
 - a) Particulate downstream of the filter may be the result of a system not being purged prior to installation and startup.
 - b) The Poro-Carbon tube element may be cracked or broken.
 - c) The Poro-Carbon tube element end gaskets may be missing or not correctly installed.

For further technical support, please contact your local R. P. Adams sales representative or the factory at the address and telephone number found on the cover of this brochure.

7) PARTS LIST FOR STANDARD GP STEAM FILTERS

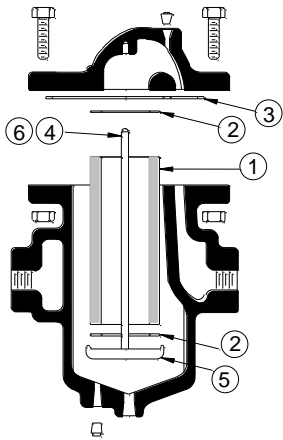

1/2" TO 3"
GP FILTERS

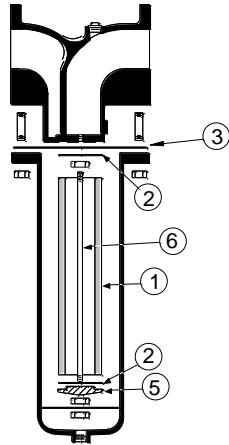

4" GP-508
150 PSIG
NONCODE ONLY

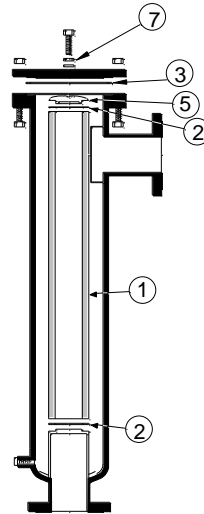

4" GP-508-HD
150 PSIG & 300 PSIG
ASME ONLY

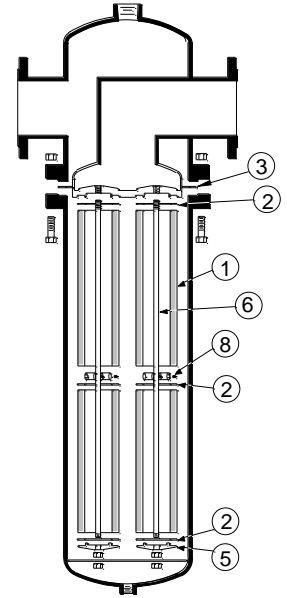

6" GP-1527

Note: Tube Holder assembly is a one-piece part that consists of a closure plate and suspension rod. The 3" GP uses a separate closure plate and suspension rod.

PARTS LIST BY MODEL

	Poro-Carbon Tube	Tube Gasket	Cover Gasket	Tube Holder Assembly	Tube Closure Plate	Tube Suspension Rod	Centering Screw Gasket
Item No.	1	2	3	4	5	6	7
1/2" GP-22	121789	121808	121804	49545-001			
3/4" GP-31	121789	121808	121804	49545-001			
1" GP-47	121790	121808	121804	49545-002			
1 1/2" GP-99	121791	121809	121805	49552-001			
2" GP-132	121792	121809	121805	49552-002			
3" GP-283	121959	122519	122518		50537-001	50536-001	
4" GP-508 150 PSIG Noncode	18144-001	122392	122522		15405-002	14359-001	
4" GP-508-HD 150 & 300 PSIG ASME	18144-001	122392	122393		101632		116414
6" GP-1527	Top 25418-001 Bott 104424	122395	123499		15405-002	26708-001	