

# R.P. ADAMS

A SUBSIDIARY OF SERVICE FILTRATION CORPORATION

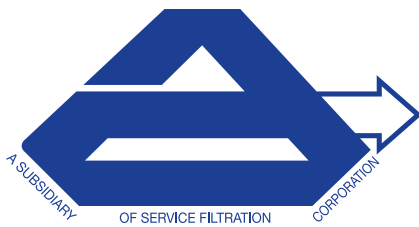

## Fabricated Strainers



# Table Of Contents

## RPA Series Fabricated Strainers

Fabricated Strainers	2
RPA Series TB, TC and TP Temporary Strainers	3
RPA Series Y125 and Y150 Fabricated Y-Strainers	5
RPA Series T150, T300 and T600 Tee Strainers	7
Dimensional Data RPA Series T150 Tee Strainers	8
Dimensional Data RPA Series T300 Tee Strainers	9
Dimensional Data RPA Series T600 Tee Strainers	10
RPA Series B150, B300 and B600 Fabricated Basket Strainers	11
Dimensional Data RPA Series B150 Fabricated Basket Strainers	12
Dimensional Data RPA Series B300 Fabricated Basket Strainers	13
Dimensional Data RPA Series B600 Fabricated Basket Strainers	14
RPA Series DB125 Duplex Strainers	15
RPA Series DB150 Duplex Strainers	17
Dimensional Data RPA Series DB150 – Style 1 Duplex Strainers	18
Dimensional Data RPA Series DB150 – Style 2 Duplex Strainers	19
Dimensional Data RPA Series DB150 – Style 3 Duplex Strainers	20
Quick Opening Covers and Cover Removal Aids	21
Replacement Baskets and Screens	23

## Engineering Data

Screen Openings	24
Temporary Strainer Pressure Drop – Liquids	25
Fabricated Y and Tee Strainer Pressure Drop – Liquids	26
Fabricated Basket and Duplex Strainer Pressure Drop – Liquids	27
Screen Correction Factor Chart	28
Viscosity and Density Correction Factor Chart	28
Correction Factors for Clogged Screens	29
Temporary Strainer Burst Pressure – Series TB	30
Temporary Strainer Burst Pressure – Series TC	31
Y-Strainer Screen Burst Pressure	32
Tee Strainer Screen Burst Pressure	33
Basket and Duplex Strainer Basket Burst Pressure	34
Effective Areas	35
Checklist and Suggested Specifications for RPA Fabricated Products	36
Installation and Maintenance Instructions for RPA Fabricated Strainers	37
Limited Warranty	37
How To Order	38

**Notes:** The material in this catalogue is for general information. For specific performance data and proper material selection, consult factory or your RPA representative. Although every attempt has been made to ensure that the information contained in this catalogue is correct RPA Inc. reserves the right to change designs, materials and/or specifications without notice.

## Limited Warranty

All products are warranted to be free of defects in material and workmanship for a period of one year from the date of shipment, subject to the limitations below: If the purchaser believes a product defective, the purchaser shall: **(a)** Notify the manufacturer, state the alleged defect and request permission to return the product. **(b)** If permission is given, return the product with transportation prepaid. If the product is accepted for return and found to be defective, the manufacturer will, at its discretion, either repair or

replace the product, f.o.b. factory, within 60 days of receipt, or refund the purchase price.

**Other than to repair, replace or refund described above, the purchaser agrees that the manufacturer shall not be liable for any losses, costs, expenses or damages of any kind arising out of the product, its use, installation or replacement, labeling, instructions, information or technical data of any kind, description of product use, sample or model, warnings or lack of foregoing. No other warranties,**

**written or oral, expressed or implied, including the warranties of fitness for a particular purpose and merchantability, are made or authorized.**

**No affirmation of fact, promise, description of product use or sample or model shall create any warranty from the manufacturer, unless signed by the president. These products are not manufactured, sold or intended for personal, family or household purposes.**

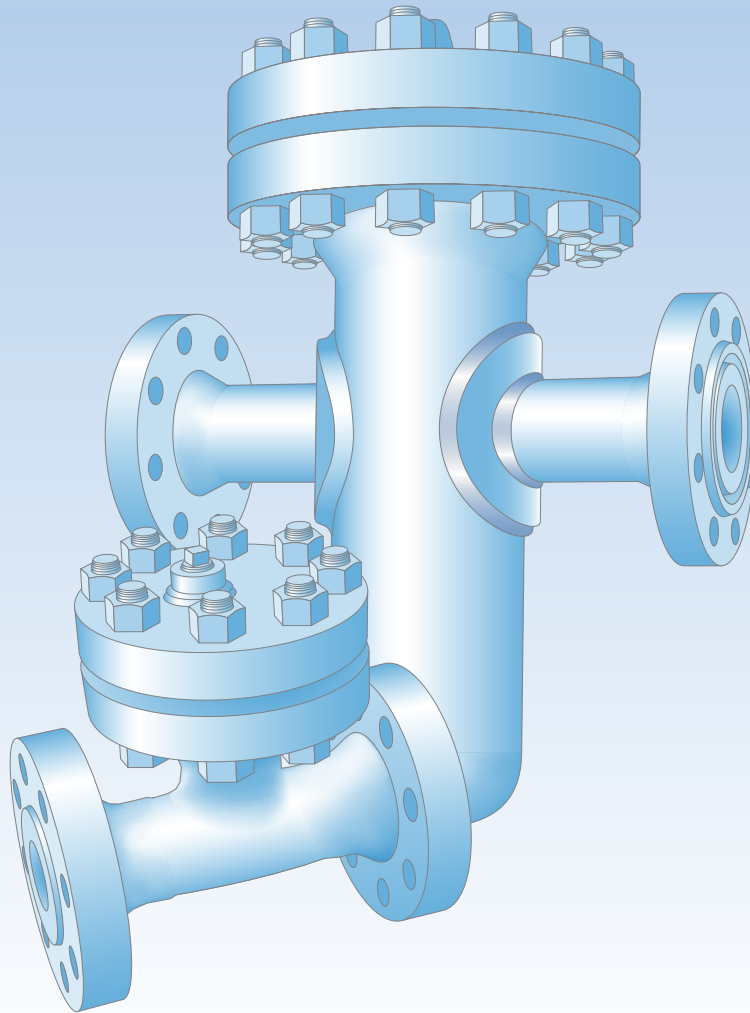
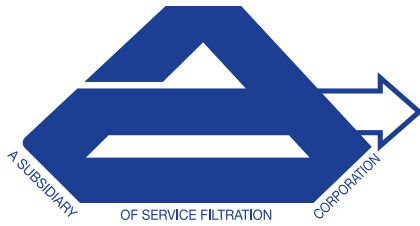

### Products:

- Standard line of Temporary, Tee, Y, Basket and Duplex strainers.
- Custom strainers to meet individual space or performance requirements.
- Automated self-cleaning strainers/systems.
- Screens and baskets.

### Available Materials of Construction:

- Carbon Steel
- Low Temp. Carbon Steel
- Stainless Steel
- Chrome Molly
- Monel
- Alloy 20
- Hastelloy
- Titanium

### End Connections:

- Flat Faced
- Raised Face
- RTJ Flanged
- Butt-weld
- Grooved
- Threaded (NPT)
- Socket Weld

### Size Range:

- 1/4" (8mm) and larger

### Applications:

- Process Industry
- Power Industry
- Chemical Industry
- Oil and Gas
- Pulp and Paper
- Metals and Mining
- Water and Waste

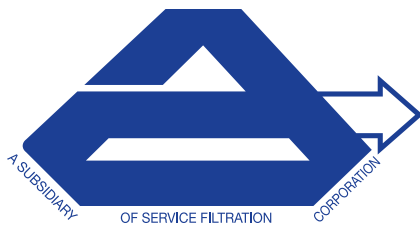

# RPA Series TB, TC and TP Temporary Strainers

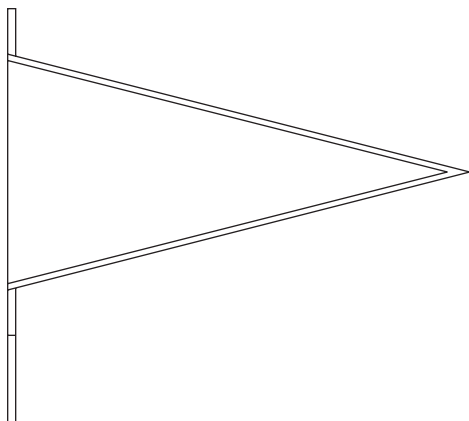

## Design Features:

- Standard sizes from 3/4" - 48".
- Used primarily for new pipeline start-up or where solid loading is minimal.
- Filtration as fine as 40 microns available.
- Available in conical, basket and plate configurations.
- Available flat faced, raised face or RTJ with or without face serrations.
- All 304 SS construction is standard. Construction in other materials is available (i.e carbon steel, monel, hastelloy, titanium, etc.).
- May be installed in horizontal or vertical pipelines with cone pointed upstream or downstream.
- Strainer size and pressure rating is stamped on handle.

Parts List and Standard Materials		
Part	Carbon Steel	304 Stainless Steel
Ring	A36	A240-304
Handle	A36	A240-304
Perforated Plate	A36	A240-304
Mesh <sup>1</sup>	A276-304	A276-304

- Notes:**
1. Strainers suitable for large differential pressures are available. Please see page 30 for standard ratings.
  2. Mesh lined strainers manufactured for unidirectional flow cannot be used for bi-directional flow. Please specify the bi-directional flow requirement when ordering.
  3. Please specify if handles are to be stamped with tag numbers when ordering.

**Note:** 1. When required and when used.

## Standard Construction Details

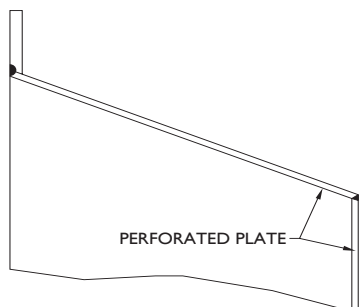

**PERFORATED PLATE**

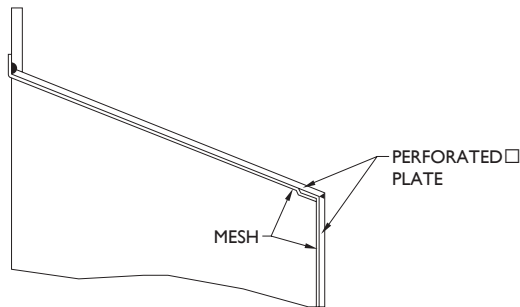

**MESH INSIDE  
FLOW INSIDE TO OUT**

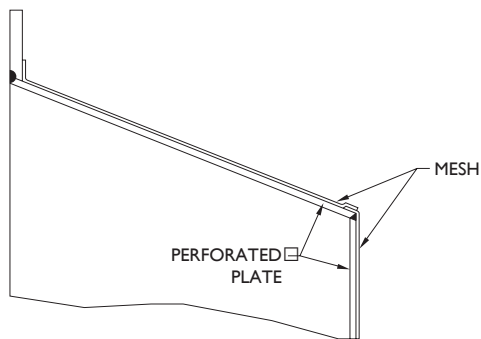

**MESH OUTSIDE  
FLOW OUTSIDE TO IN**

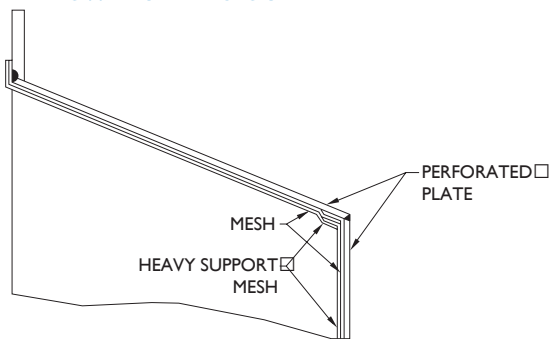

**MESH LINED  
BI-DIRECTIONAL FLOW**

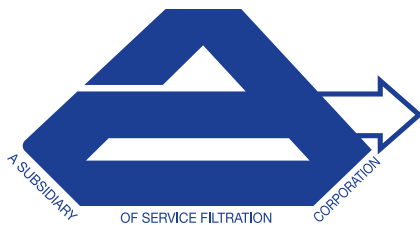

# RPA Series TB, TC and TP Temporary Strainers

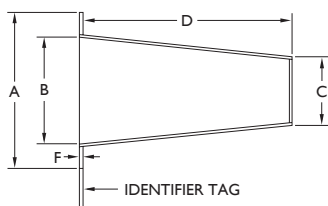

**BASKET TYPE (TB)**

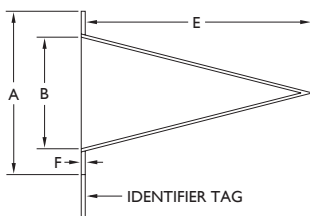

**CONICAL TYPE (TC)**

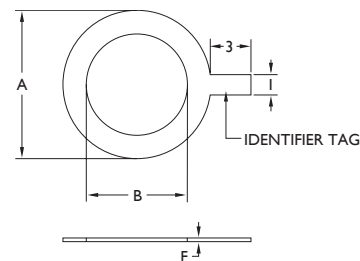

**PLATE TYPE (TP)**

## Standard Screens

Size Range	Opening	Gauge Thickness
3/4" - 8" (20mm - 200mm)	0.125 in. (3.2mm)	22
10" - 24" (250mm - 600mm)	0.125 in. (3.2mm)	16

## Parts List and Standard Materials

Size in. (mm)	A (O.D.) in. (mm)				B (I.D.) in. (mm)	C in. (mm)	D (Basket Length) in. (mm)				E (Cone Length) in. (mm)				F <sup>2</sup> in. (mm)	Weight Lbs. (Kg.)
	150/ #600#	300/ #900#	1500/ #				100%	150%	200%	300%	100%	150%	200%	300%		
3/4"	2.13	2.50	2.63	2.63	0.63	0.31	0.75	1.13	1.50	2.25	1.13	1.69	2.25	3.38	0.13	0.5
20	54	64	67	67	16	8	19	29	38	57	29	43	57	86	3	0.2
1"	2.50	2.75	3.00	3.00	0.75	0.38	1.13	1.69	2.25	3.38	1.63	2.50	3.31	5.00	0.13	0.5
25	64	70	76	76	19	10	29	43	57	86	41	64	84	127	3	0.2
1 1/2"	3.25	3.63	3.75	3.75	1.25	0.63	1.50	2.25	3.00	4.50	2.19	3.38	4.50	6.75	0.13	0.5
40	83	92	95	95	32	16	38	57	76	114	56	86	114	171	3	0.2
2"	4.00	4.25	5.50	5.50	1.75	0.88	2.00	3.00	4.00	6.00	3.00	4.50	6.00	9.13	0.13	0.5
50	102	108	140	140	44	22	51	76	102	152	76	114	152	232	3	0.2
2 1/2"	4.75	5.00	6.38	6.38	2.25	1.13	2.19	3.37	4.50	6.75	3.19	5.00	6.69	10.13	0.13	1
65	121	127	162	162	57	29	56	86	114	171	81	127	170	257	3	0.5
3"	5.25	5.75	6.50	6.75	2.75	1.38	2.75	4.25	5.69	8.50	4.00	6.25	8.50	12.75	0.13	1
80	133	146	165	171	70	35	70	1.08	145	216	102	159	216	324	3	0.5
4"	6.75	7.50	8.00	8.13	3.75	1.88	3.50	5.32	7.19	11.00	5.13	7.88	10.63	17.00	0.13	2
100	171	191	203	206	95	48	89	135	183	279	130	200	270	432	3	0.9
5"	7.63	9.38	9.63	9.88	4.63	2.31	4.50	6.75	9.13	14.00	6.50	10.13	14.00	21.00	0.13	2
125	194	238	244	251	117	59	114	171	232	356	165	257	356	533	3	0.9
6"	8.63	10.37	11.25	11.00	5.38	2.69	5.50	8.50	11.37	17.00	8.13	13.00	17.00	26.00	0.13	3
150	219	263	286	279	137	68	140	216	289	432	207	330	432	660	3	1.4
8"	10.87	12.50	14.00	13.75	7.38	3.69	7.00	10.69	15.00	22.00	10.19	16.00	22.00	33.00	0.13	5
200	276	318	356	349	187	94	178	272	381	559	259	406	559	838	3	2.3
10"	13.25	15.63	17.00	17.00	9.38	4.69	8.63	14.00	18.00	27.00	13.00	20.00	27.00	40.00	0.13	7
250	337	397	432	432	238	119	219	356	457	686	330	508	686	1016	3	3.2
12"	16.00	17.87	19.50	20.37	11.00	5.50	10.50	17.00	22.00	33.00	16.00	24.00	33.00	49.00	0.13	11
300	406	454	495	517	279	140	267	432	559	838	406	610	838	1245	3	5.0
14"	17.37	19.00	20.37	22.62	12.25	6.13	11.50	18.00	24.00	36.00	17.00	27.00	36.00	54.00	0.13	12
350	441	483	517	575	311	156	292	457	610	914	432	686	914	1372	3	5.4
16"	20.12	21.87	22.50	25.13	14.00	7.00	14.00	21.00	28.00	42.00	20.00	31.00	41.00	62.00	0.13	16
400	511	555	572	638	356	178	356	533	711	1067	508	787	1041	1575	3	7.3
18"	21.25	23.75	25.00	27.63	15.75	7.88	16.00	24.00	32.00	47.00	23.00	35.00	47.00	71.00	0.13	20
450	540	603	635	702	400	200	406	610	813	1194	584	889	1194	1803	3	9.1
20"	23.50	26.62	27.38	29.63	17.50	8.75	17.00	27.00	35.00	53.00	25.00	39.00	53.00	79.00	0.13	26
500	597	676	695	753	445	222	432	686	889	1346	635	991	1346	2007	3	11.8
24"	27.87	30.87	32.88	35.38	21.25	10.63	21.00	32.00	42.00	64.00	30.00	47.00	63.00	95.00	0.13	30
600	708	784	835	899	540	270	533	813	1067	1626	762	1194	1600	2413	3	13.6

**Notes:** 1. The Open Area % is calculated as follows:

$$OA\% = \frac{\text{Screen Area} \times 0.4}{\text{Area of Sch. 40/std. pipe.}} \times 100$$

### General:

- For further optional features see pages 21-22.
- Other perforations and screen materials available. Please see page 24.

- Thicker material available upon request. Please contact factory.
- Strainers are available in many materials with many different screen openings. Please consult factory.
- Other sizes available on request.

- For pressure loss information see page 25.
- For ordering information please see page 38.
- Dimensions shown are subject to change. Contact factory for certified prints when required.

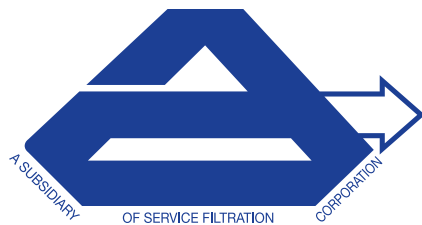

# RPA Series Y125 and Y150 Fabricated Y-Strainers

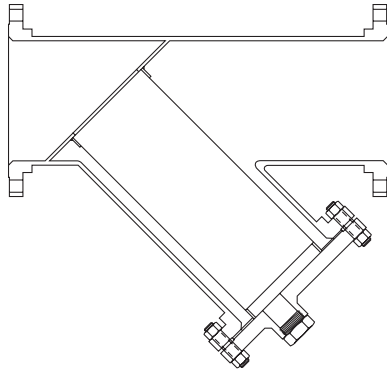

## Design Features:

- Standard sizes from 2" - 24".
- Available with RF or RTJ flanged (ASME B16.5), Buttweld (ASME B16.9) or grooved end connections.
- Standard thru bolt or grooved cover design.
- Custom modifications are available.
- May be installed in horizontal or vertical pipelines.
- All welders are qualified to ASME Section IX.
- Strainers designed to meet the requirements of ASME B31.1 and/or ASME B31.3.
- 304 SS perforated screens are standard.
- Drains connections are standard and are furnished with plug.
- Vents, differentials and special covers are optional.

## Parts List and Standard Materials (Flanged End)

Part	Carbon Steel	Stainless Steel <sup>1</sup>
Shell & Nozzles	A53 E/B / A106-B	A312
Reinforcement Pads <sup>2</sup>	A516-70	A240
Flanges	A105	A182
Coupling/threadolet:	A105	A182
Plug	A105	A182
Screen Retainer Ring	A36	A240
Screen <sup>3</sup>	304 SS	304 SS
Gasket <sup>3</sup>	304 SS Spiral Wound	304 SS Spiral Wound
Stud	A193-B7	A193-B8-1
Nut	A194-2H	A194-8

- Notes:** 1. 304 SS strainers use 304 grade material. 316 SS strainers use 316 grade material. Dual rated material may be used.  
2. When required and when used.  
3. Recommended Spares.

## Parts List and Standard Materials (Grooved End)

Part	Stainless Steel
Shell & Nozzles	A312-304
Flanges	A36 Zinc Plated
Plug	B584 Brass
Cover	Sizes 2 1/2" - 5" & 12": Ductile Iron Sizes 6" - 10": 304 SS
Screen <sup>1</sup>	304 SS
Gasket <sup>1</sup>	EPDM
Bolts	B633
Nuts	B633

- Notes:** 1. Recommended Spares.  
2. Lead-free construction complies with California Prop. 65 and proposed Federal Government lead-free standards.  
3. Single, two-bolt, grooved style cover provides quick and easy access to screen.

## Upper Pressure Limits (Non-Shock) and Lower Temperature Limits (Unless otherwise specified)

RPA Model	Body Material	Size Range in. (mm)	Maximum Design Pressure psig (Bars) <sup>1</sup>	Low Temperature Limit— M.D.M.T. — °F (°C)
Y125FSBW	Carbon Steel	2" - 12" (50mm - 300mm)	200 (13.79) <sup>2</sup>	-20 (-28.9)
		14" - 24" (350mm - 600mm)	150 (10.34) <sup>2</sup>	-20 (-28.9)
Y125GSS4GW	304 SS	2 1/2" - 12" (65mm - 300mm)	200 (13.79) <sup>2</sup>	-20 (-28.9)
Y125FSS4BW / Y125FSS6BW	304 / 316 SS	2" - 12" (50mm - 300mm)	200 (13.79) <sup>2</sup>	-20 (-28.9)
		14" - 24" (350mm - 600mm)	150 (10.34) <sup>2</sup>	-20 (-28.9)
Y125FSS4LBW / Y125FSS6LBW	304L / 316L SS	2" - 12" (50mm - 300mm)	200 (13.79) <sup>2</sup>	-20 (-28.9)
		14" - 24" (350mm - 600mm)	150 (10.34) <sup>2</sup>	-20 (-28.9)
Y150FSBW	Carbon Steel	2" - 12" (50mm - 300mm)	285 (19.65) <sup>3</sup>	-20 (-28.9)
Y150FSS4BW / Y150FSS6BW	304 / 316 SS	2" - 12" (50mm - 300mm)	275 (18.96) <sup>3</sup>	-20 (-28.9)
Y150FSS4LBW / Y150FSS6LBW	304L / 316L SS	2" - 12" (50mm - 300mm)	230 (15.86) <sup>3</sup>	-20 (-28.9)

- Notes:** 1. All strainers will be designed to the maximum design pressure unless an alternative design pressure / temperature combination is specified. In many cases a cost savings will result if lower design pressures are acceptable.  
2. M.A.W.P. at 150°F.  
3. M.A.W.P. at 100°F.

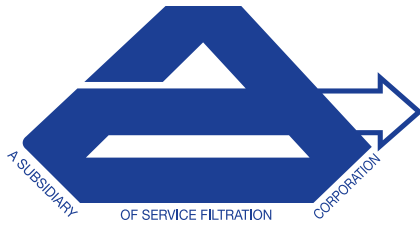

# RPA Series Y125, Y150 and Y125GSS4GW Dimensions

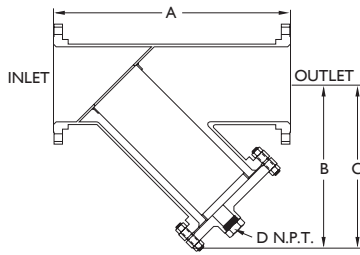

**SERIES Y150F**

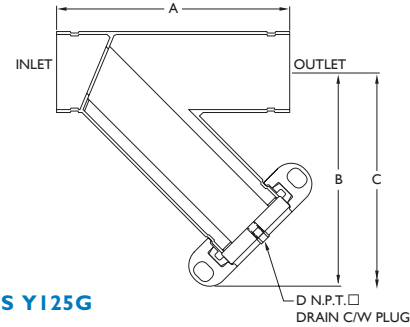

**SERIES Y125G**

## Standard Screens

Flanged End		Grooved End	
Size Range	Opening	Size range	Opening
2" - 8" (50mm - 200mm)	0.125 in. (3.2mm)	2.5" - 5" (65mm - 125mm)	0.063 in. (1.5mm)
10" - 12" (250mm - 300mm)	0.125 in. (3.2mm)	6" - 8" (150mm - 200mm)	0.125 in. (3.2mm)
14" - 24" (350mm - 600mm)	0.188 in. (4.8mm)	10" - 12" (250mm - 300mm)	0.188 in. (4.8mm)

## Dimensional Data

Size in. (mm)	A in. (mm)		B in. (mm)		C in. (mm)		D in. (mm)		Weight Lb. (kg.)					
	Flanged	Grooved	Flanged	Grooved	Flanged	Grooved	Flanged	Grooved	Cover		Unit			
End type	Flanged	Grooved	Flanged	Grooved	Flanged	Grooved	Flanged	Grooved	Flanged	Grooved	Flanged	Grooved	Flanged	Grooved
2" 50	10.81 275	-	8.25 210	-	13.25 337	-	1/2 15	-	5 2	-	28 13	-	-	-
2 1/2" 65	13.38 340	9.5 241	10.25 260	8.81 224	16.44 418	14.06 357	1 25	1/2 15	9 4	1 0.45	81 37	21 10	-	-
3" 80	13.38 340	9.63 244	10.25 260	9.25 235	16.44 418	14.75 375	1 25	1/2 15	9 4	1.2 0.54	81 37	26 12	-	-
4" 100	14.75 375	11.63 295	10.50 267	11.25 286	16.75 425	18.50 470	1 1/2 40	1/2 15	17 8	2.5 1.13	85 39	33 15	-	-
5" 125	17.25 438	15.13 384	12.50 318	13.25 337	20.00 508	21.00 533	1 1/2 40	1/2 15	20 9	4.6 2.08	110 50	46 21	-	-
6" 150	22.00 559	18.00 457	14.00 356	15.81 402	22.44 570	25.75 654	2 50	3/4 20	26 12	1.6 0.72	145 66	70 32	-	-
8" 200	24.00 610	21.13 537	17.75 451	19.63 499	28.44 722	32.31 821	2 50	3/4 20	45 20	3.1 6	256 116	91 41	-	-
10" 250	31.50 800	25.50 648	22.00 559	24.69 627	35.25 895	41.00 1041	2 50	3/4 20	70 32	4.6 2	380 172	134 61	-	-
12" 300	32.75 832	29.38 746	25.00 635	27.88 708	40.00 1016	47.00 1194	2 50	3/4 20	110 50	36 16	700 317	225 102	-	-
14" 350	39.75 1010	-	27.00 686	-	43.25 1099	-	2 50	-	140 63	-	750 340	-	-	-
16" 400	45.25 1149	-	30.88 784	-	49.50 1257	-	2 50	-	180 82	-	905 410	-	-	-
18" 450	48.50 1232	-	33.88 861	-	54.25 1378	-	2 50	-	220 100	-	1125 510	-	-	-
20" 500	53.75 1365	-	39.00 991	-	62.50 1588	-	2 50	-	285 129	-	1415 641	-	-	-
24" 600	64.00 1626	-	44.00 1118	-	70.50 1791	-	2 50	-	430 195	-	1825 827	-	-	-

**Notes:** 1. Differentials are optional.

2. Butt weld dimensions are same as flanged.

**General:**

1. For further optional features see pages 21-22.

2. Other perforations and screen materials available.

Please see page 24.

3. For pressure loss information see page 25.

4. For ordering information please see page 38.

5. Dimensions shown are subject to change.

Contact factory for certified prints when required.

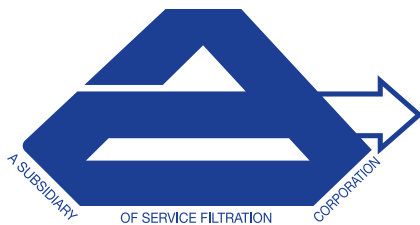

# RPA Series T150, T300 and T600 Tee Strainers

## Design Features:

- Standard Sizes from 2" - 24". Larger sizes available upon request.
- Available with RF or RTJ flanged (ASME B16.5) or Buttweld (ASME B16.9) end connections.
- Standard thru bolt cover design.
- Three flow configurations are available.
- 304 SS perforated screens are standard.
- Upstream and downstream screen supports allow for bi-directional flow <sup>1</sup>.
- May be installed in horizontal or vertical pipelines.
- All welders are qualified to ASME Section IX.
- Strainers designed to meet the requirements of ASME B31.1, ASME B31.3 and/or ASME Section VIII, Div. 1.
- Drains, vents, differentials and special covers are optional.

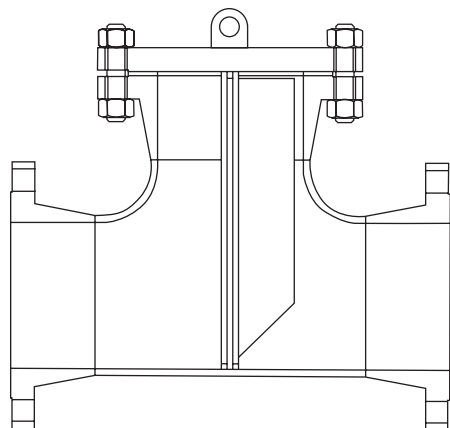

**Notes:** 1. This requirement must be specified for strainer screens requiring mesh lining.

## Parts List and Standard Materials

Part	Carbon Steel	Low Temp. Carbon Steel (-50°F)	Stainless Steel <sup>1</sup>
Body	A234-WPB	A420-WPL6	A403-WVP
Flanges	A105	A350-LF2	A182
Screen <sup>2</sup>	304 SS	304 SS	304 SS
Internal support ribs:	Carbon Steel	304 SS	304 SS
Coupling/threadolets	A105	A350-LF2	A182
Plug <sup>3</sup>	A105	A350-LF2	A182
Gasket <sup>2</sup>	304 SS Spiral Wound	304 SS Spiral Wound	304 SS Spiral Wound
Stud	A193-B7	A193-B7	A193-B8-1
Nut	A194-2H	A194-2H	A194-8

**Notes:** 1. 304SS strainers use 304 grade material. 316SS strainers use 316 grade material. Dual rated material may be used.

2. Recommended Spares.

3. When required and when used.

4. NACE MR01-75 qualification available upon request. Material specifications will change.

5. Also available in other alloys.

## Upper Pressure Limits (Non-Shock) and Lower Temperature Limits (Unless otherwise specified)

RPA Model (RF Flanged)	Body Material	Maximum Design Pressure— at 100°F — psig (Bars) <sup>1</sup>	Lower Temperature Limit — M.D.M.T. — °F (°C)
T150FSBW	Carbon Steel	285 (19.65)	-20 (-28.9)
T150FLCBW	Low Temp. Carbon Steel	285 (19.65)	-50 (-45.6)
T150FSS4BW / T150FSS6BW	304 / 316 SS	275 (18.96)	-20 (-28.9) Optional -425 (-253.9)
T150FSS4LBW / T150FSS6LBW	304L / 316L SS	230 (15.86)	-20 (-28.9) Optional -425 (-253.9)
T300FSBW	Carbon Steel	740 (51.02)	-20 (-28.9)
T300FLCBW	Low Temp. Carbon Steel	740 (51.02)	-50 (-45.6)
T300FSS4BW / T300FSS6BW	304 / 316 SS	720 (49.64)	-20 (-28.9) Optional -425 (-253.9)
T300FSS4LBW / T300FSS6LBW	304L / 316L SS	600 (41.37)	-20 (-28.9) Optional -425 (-253.9)
T600FSBW	Carbon Steel	1480 (102.04)	-20 (-28.9)
T600FLCBW	Low Temp. Carbon Steel	1480 (102.04)	-50 (-45.6)
T600FSS4BW / T600FSS6BW	304 / 316 SS	1440 (99.28)	-20 (-28.9) Optional -425 (-253.9)
T600SS4LBW / T600FSS6LBW	304L / 316L SS	1200 (82.74)	-20 (-28.9) Optional -425 (-253.9)

**Notes:** 1. All strainers will be designed to the maximum design pressure at 100°F unless an alternative design pressure / temperature combination is specified.

2. Lower and higher M.D.M.T.s are available upon request.



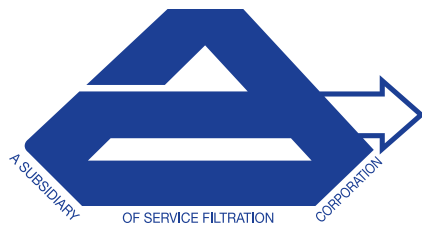

# RPA Series T150 Dimensional Data

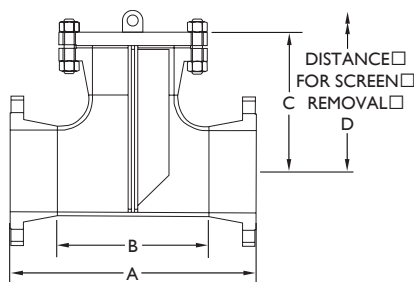

**STYLE 1**

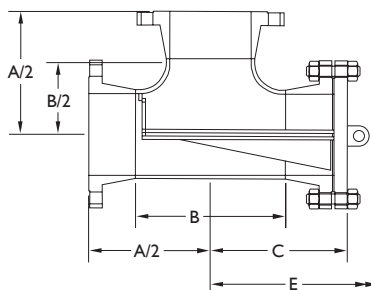

**STYLE 2**

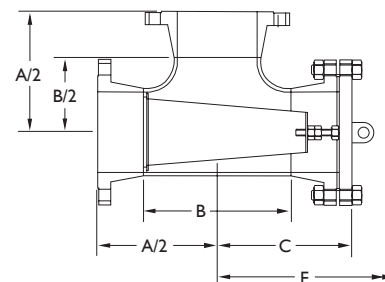

**STYLE 3**

## Standard Screens

Size Range	Opening	Gauge Thickness
2" - 8" (50mm - 200mm)	0.125 in. (3.2mm)	22
10" - 12" (250mm - 300mm)	0.125 in. (3.2mm)	16
14" - 24" (350mm - 600mm)	0.188 in. (4.8mm)	11

## Dimensional Data

Size in. (mm)	A in. (mm)	B in. (mm)	C in. (mm)	D in. (mm)	E in. (mm)	Weight Lb. (kg.)		
						Cover	Unit Flanged	Buttweld
2"	10.00	5.00	5.75	11.00	12.50	5	28	16
50	254	127	146	279	318	2	13	7
3"	12.25	6.75	7.06	13.75	15.25	9	52	32
80	311	172	179	349	387	4	24	15
4"	14.25	8.25	8.06	16.25	18.38	17	79	49
100	362	210	205	413	467	8	36	22
5"	16.75	9.75	9.31	19.25	21.63	20	105	67
125	425	248	237	489	549	9	8	30
6"	18.25	11.25	10.13	21.25	23.68	26	140	92
150	464	286	257	540	606	12	64	42
8"	22.00	14.00	12.13	26.00	29.00	45	230	152
200	559	356	308	660	737	20	104	69
10"	25.00	17.00	13.69	30.00	33.50	70	325	221
250	635	432	348	762	851	32	148	100
12"	29.00	20.00	15.75	35.00	39.00	110	500	340
300	737	508	400	889	991	50	227	154
14"	32.00	22.00	17.38	39.00	43.00	140	710	490
350	813	559	441	991	1092	64	322	222
16"	34.00	24.00	18.44	42.00	46.00	180	860	580
400	864	610	468	1067	1168	82	390	263
18"	38.00	27.00	20.56	47.00	51.50	220	1025	725
450	965	686	522	1194	1308	100	465	329
20"	41.36	30.00	22.38	51.38	56.38	285	1350	990
500	1051	762	568	1305	1432	129	613	449
24"	46.00	34.00	24.88	58.00	63.00	430	2100	1580
600	1168	864	632	1473	1600	195	953	717

**Notes:** 1. Drains and differentials are optional.

2. Cover lifting lug standard on sizes 10" and larger.

**General:**

1. For further optional features see pages 21-22.

2. Other perforations and screen materials available. Please see page 24.

3. For pressure loss information see page 25.

4. For ordering information please see page 38.

5. Dimensions shown are subject to change.

Contact factory for certified prints when required.

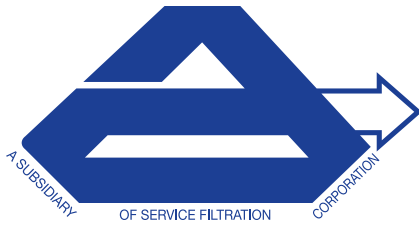

# RPA Series T300 Dimensional Data

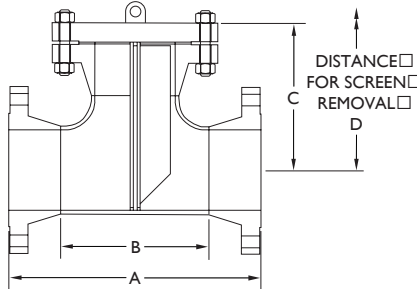

**STYLE 1**

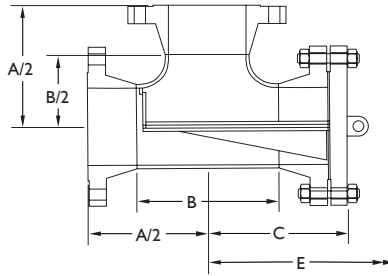

**STYLE 2**

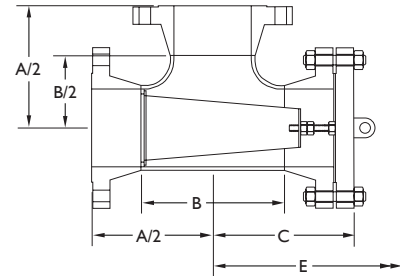

**STYLE 3**

## Standard Screens

Size Range	Opening	Gauge Thickness
2" - 8" (50mm - 200mm)	0.125 in. (3.2mm)	22
10" - 12" (250mm - 300mm)	0.125 in. (3.2mm)	16
14" - 24" (350mm - 600mm)	0.188 in. (4.8mm)	11

## Dimensional Data

Size in. (mm)	A in. (mm)	B in. (mm)	C in. (mm)	D in. (mm)	E in. (mm)	Weight Lb. (kg.)		
						Cover	Unit Flanged	Buttweld
2"	10.50	5.00	6.13	11.50	13.00	8	42	24
50	267	127	156	292	330	4	19	11
3"	13.00	6.75	7.63	14.50	16.00	16	72	42
80	330	172	194	368	406	7	33	19
4"	15.00	8.25	8.75	17.00	19.13	27	125	75
100	381	210	222	432	486	12	57	34
5"	17.50	9.75	10.13	20.00	22.38	35	160	96
125	445	248	257	508	568	16	73	44
6"	19.00	11.25	10.94	22.00	24.63	50	225	141
150	483	286	278	559	625	23	102	62
8"	22.75	14.00	13.00	26.75	29.75	81	350	216
200	578	356	330	679	756	37	159	98
10"	26.25	17.00	15.00	31.25	34.75	124	495	313
250	667	432	381	794	883	56	225	142
12"	30.25	20.00	17.13	36.25	40.25	185	765	485
300	768	508	435	921	1022	84	347	220
14"	33.25	22.00	18.75	40.25	44.25	250	1025	665
350	845	559	476	1022	1124	114	465	302
16"	35.50	24.00	20.00	43.50	47.50	295	1320	820
400	902	610	508	1105	1207	134	599	372
18"	39.50	27.00	22.13	48.50	53.00	395	1700	1060
450	1003	686	562	1232	1346	179	772	481
20"	32.75	30.00	23.88	42.75	47.75	505	2250	1450
500	832	762	606	1086	1213	229	1022	658
24"	47.25	34.00	26.38	59.25	64.25	790	2340	2240
600	1200	864	670	1505	1632	359	1544	1017

**Notes:** 1. Drains and differentials are optional.  
2. Cover lifting lug standard on sizes 8" and larger.

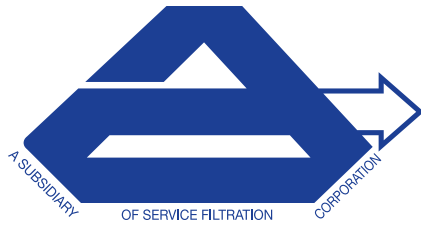

# RPA Series T600 Dimensional Data

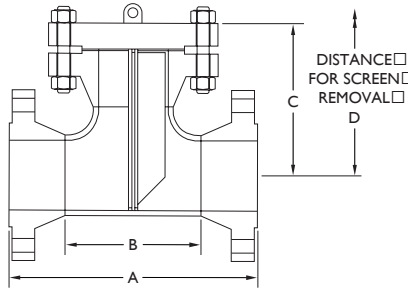

**STYLE 1**

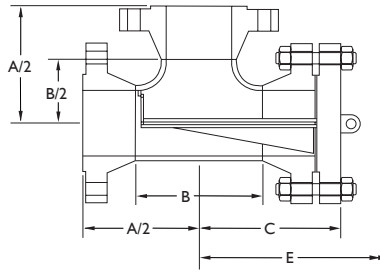

**STYLE 2**

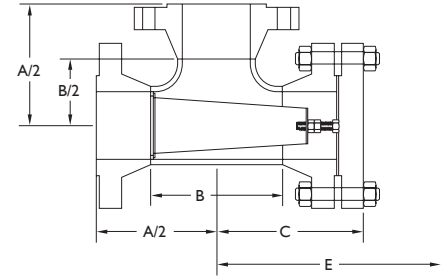

**STYLE 3**

## Standard Screens

Size Range	Opening	Gauge Thickness
2" - 8" (50mm - 200mm)	0.125 in. (3.2mm)	22
10" - 12" (250mm - 300mm)	0.125 in. (3.2mm)	16
14" - 24" (350mm - 600mm)	0.188 in. (4.8mm)	11

## Dimensional Data

Size in. (mm)	A in. (mm)	B in. (mm)	C in. (mm)	D in. (mm)	E in. (mm)	Weight Lb. (kg.) Unit		
						Cover	Flanged	Buttweld
2"	11.25	5.00	6.88	12.25	13.75	10	52	28
50	286	127	175	311	349	5	24	13
3"	13.75	6.75	8.38	15.25	16.75	20	100	54
80	349	172	213	387	425	9	45	25
4"	16.75	8.25	10.13	18.75	20.88	41	190	106
100	425	210	257	476	530	19	86	48
5"	19.25	9.75	11.63	21.75	24.13	68	295	159
125	489	248	295	552	613	31	134	72
6"	21.00	11.25	12.63	24.00	25.63	86	365	203
150	533	286	321	610	676	39	166	92
8"	25.00	14.00	14.94	29.00	32.00	140	580	340
200	635	356	379	737	813	64	263	154
10"	29.50	17.00	17.50	34.50	38.00	230	900	520
250	749	432	445	876	965	104	409	236
12"	32.75	20.00	19.25	38.75	42.75	295	1150	700
300	832	508	489	984	1086	134	522	318
14"	35.50	22.00	20.75	42.50	46.50	355	1480	920
350	902	559	527	1080	1181	161	672	418
16"	38.50	24.00	22.50	46.50	50.50	495	1950	1170
400	978	610	572	1181	1283	225	885	531
18"	42.00	27.00	24.50	51.00	55.50	630	2450	1500
450	1067	686	622	1295	1410	286	1112	681
20"	45.50	30.00	26.50	55.50	60.50	810	3150	1970
500	1156	762	673	1410	1537	368	1430	894
24"	50.50	34.00	29.50	62.50	67.50	1250	4600	2940
600	1283	864	749	1588	1715	568	2088	1335

- Notes:** 1. Drains and differentials are optional.  
2. Cover lifting lug standard on sizes 6" and larger.

- General:**  
1. For further optional features see pages 21-22.  
2. Other perforations and screen materials available. Please see page 24.

3. For pressure loss information see page 25.  
4. For ordering information please see page 38.  
5. Dimensions shown are subject to change. Contact factory for certified prints when required.

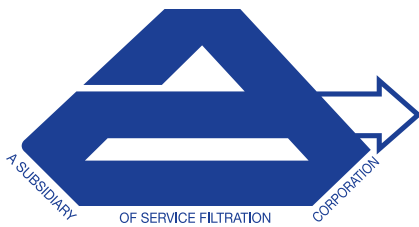

# RPA Series B125, B150, B300 and B600 Fabricated Basket Strainers

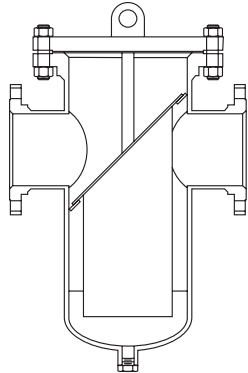

## Design Features:

- Standard sizes from 2" - 24". Larger sizes available upon request.
- Available with RF or RTJ flanged (ASME B16.5) or Buttweld (ASME B16.9) end connections.
- Standard thru bolt cover design.
- Custom designs are available.
- Perforated screens are standard.
- May be installed in horizontal pipelines.
- All welders are qualified to ASME Section IX.
- Strainers designed to meet the requirements of ASME B31.1, ASME B31.3 and/or ASME Section VIII, Div. I.
- Drain is standard and is complete with plug.
- Vents, differentials and special covers are optional.

## Pars List and Standard Materials

Part	Carbon Steel	Low Temp. Carbon Steel (-50; F)	Stainless Steel <sup>1</sup>
Shell	A53 E/B / A106-B	A333-6	A312
Nozzles	A53 E/B / A106-B	A333-6	A312
Reinforcement Pads <sup>3</sup>	A516-70	A516-70	A240
Flanges	A105	A350-LF2	A182
Heads	A234-WPB / A516-70	A420-WPL6	A403-WVP
Coupling/threadolets	A105	A350-LF2	A182
Plug	A105	A350-LF2	A182
Basket <sup>2</sup>	304 SS	304 SS	304 SS
Gasket <sup>2</sup>	304 SS Spiral Wound	304 SS Spiral Wound	304 SS Spiral Wound
Stud	A193-B7	A193-B7	A193-B8-1
Nut	A194-2H	A194-2H	A194-8

**Notes:** 1. 304SS strainers use 304 grade material. 316SS strainers use 316 grade material. Dual rated material may be used.

2. Recommended Spares.

3. When required and when used.

4. NACE MR01-75 qualification available upon request. Material specifications will change.

5. For strainers designed to ASME Section VIII, Div. I the "A" designation becomes "SA".

## Upper Pressure Limits (Non-Shock) and Lower Temperature Limits (Unless otherwise specified)

RPA Model (Flanged)	Body Material	Maximum Design Pressure at 100;F psig (Bars) <sup>1</sup>	Lower Temperature Limit - M.D.M.T. ;F (;C)
B125FSBW5	Carbon Steel - Epoxy Coated	175 psi Water	-20 (-28.9)
B150FSBW	Carbon Steel	285 (19.65)	-20 (-28.9)
B150FLCBW	Low Temp. Carbon Steel	285 (19.65)	-50 (-45.6)
B150FSS4BW / B150FSS6BW	304 / 316 SS	275 (18.96)	-20 (-28.9) Optional -425 (-253.9)
B150FSS4LBW / B150FSS6LBW	304L / 316L SS	230 (15.86)	-20 (-28.9) Optional -425 (-253.9)
B300FSBW	Carbon Steel	740 (51.02)	-20 (-28.9)
B300FLCBW	Low Temp. Carbon Steel	740 (51.02)	-50 (-45.6)
B300FSS4BW / B300FSS6BW	304 / 316 SS	720 (49.64)	-20 (-28.9) Optional -425 (-253.9)
B300FSS4LBW / B300FSS6LBW	304L / 316L SS	600 (41.37)	-20 (-28.9) Optional -425 (-253.9)
B600FSBW	Carbon Steel	1480 (102.04)	-20 (-28.9)
B600FLCBW	Low Temp. Carbon Steel	1480 (102.04)	-50 (-45.6)
B600FSS4BW / B600FSS6BW	304 / 316 SS	1440 (99.28)	-20 (-28.9) Optional -425 (-253.9)
B600FSS4LBW / B600FSS6LBW	304L / 316L SS	1200 (82.74)	-20 (-28.9) Optional -425 (-253.9)

**Notes:** 1. All strainers will be designed to the maximum design pressure at 100°F unless an alternative design pressure / temperature combination is specified. In many cases a cost savings will result if lower design pressures are acceptable.

2. Lower and higher M.D.M.T.s are available upon request.

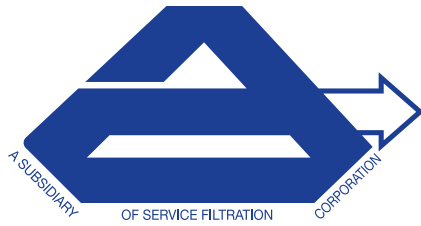

# RPA Series B125 and B150 Dimensional Data

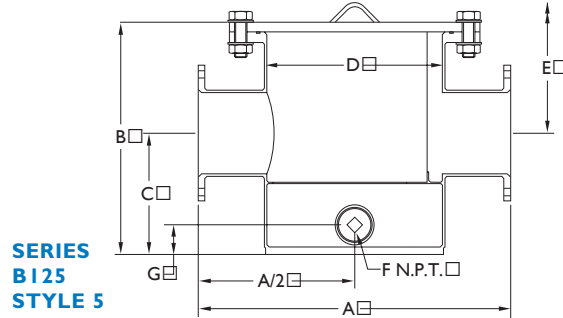
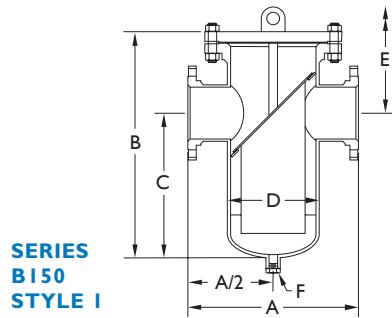

## Standard Screens

Series B150 — Style I		Series B125 — Style 5	
Size Range	Opening	Size Range	Opening
2" - 8" (50mm - 200mm)	0.125 in. (3.2mm)	3" - 10" (80mm - 250mm)	0.25 in. (6.4mm)
10" - 12" (250mm - 300mm)	0.125 in. (3.2mm)		
14" - 24" (250mm - 600mm)	0.188 in. (4.8mm)		

**Notes:** These strainers are UL Listed for Fireline Service.

## Dimensional Data

Size in. (mm)	A in. (mm)		B in. (mm)		C in. (mm)		D in. (mm)		E in. (mm)		F in. (mm)		G in. (mm)		Weight Lb. (kg) Cover Unit			
	1	5	1	5	1	5	1	5	1	5	1	5	5	1	5	1	5	
2" 50	12.75 324	-	18.63 473	-	11.13 283	-	6.63 168	-	25.00 635	-	1/2 15	-	-	26 12	-	85 39	-	
3" 80	14.00 356	14.13 359	20.50 521	18.44 468	12.50 318	10.63 270	8.63 219	8.63 219	28.50 724	26.25 667	3/4 20	2 50	2.13 54	45 20	28 13	140 63	107 48	
4" 100	16.00 406	21.00 533	22.25 565	18.44 468	14.00 356	10.63 270	8.63 219	8.63 219	30.50 775	26.25 667	1 25	2 50	2.13 54	45 20	28 13	145 66	142 64	
5" 125	18.00 457	-	24.25 616	-	17.00 432	-	10.75 273	-	30.50 775	-	1 25	-	-	70 32	-	160 72	-	
6" 150	20.00 508	26.88 683	26.50 673	20.19 513	17.00 432	11.06 281	10.75 273	14.00 356	36.00 914	29.32 745	1 25	3 80	3.00 76	70 32	64 29	205 93	303 137	
8" 200	22.00 559	31.25 794	32.00 813	22.88 581	21.00 533	12.06 306	12.75 324	18.00 457	43.00 1092	33.70 856	1 1/2 40	3 80	3.00 76	110 50	143 65	420 190	398 180	
10" 250	32.00 813	30.00 762	41.50 1054	27.13 689	25.00 635	14.81 376	16.00 406	20.00 508	58.00 1473	39.45 1002	1 1/2 40	3 80	3.25 83	180 82	184 83	650 294	463 210	
12" 300	35.00 889	-	44.75 1137	-	28.00 711	-	18.00 457	-	61.50 1562	-	1 1/2 40	-	-	220 100	-	1205 546	-	
14" 350	37.00 940	-	48.75 1238	-	33.00 838	-	20.00 508	-	64.50 1638	-	2 50	-	-	285 129	-	1600 725	-	
16" 400	42.00 1067	-	54.25 1378	-	36.00 914	-	24.00 610	-	72.50 1842	-	2 50	-	-	430 195	-	1965 890	-	
18" 450	46.50 1181	-	60.00 1524	-	40.00 1016	-	24.00 610	-	80.00 2032	-	2 50	-	-	430 195	-	2200 997	-	
20" 500	52.00 1321	-	68.00 1727	-	46.00 1168	-	30.00 762	-	90.00 2286	-	2 50	-	-	965 437	-	3200 1450	-	
24" 600	64.00 1626	-	82.75 2102	-	55.00 1397	-	36.00 914	-	110.50 2807	-	2 50	-	-	1540 698	-	4500 2039	-	

**Notes:** 1. Vents and Differentials are optional.  
2. Cover lifting lug standard on sizes 10" and larger.

**General:**  
1. For further optional features see pages 21-22.  
2. Other perforations and screen materials available. Please see page 24.

3. For pressure loss information see page 25.  
4. For ordering information please see page 38.  
5. Dimensions shown are subject to change. Contact factory for certified prints when required.

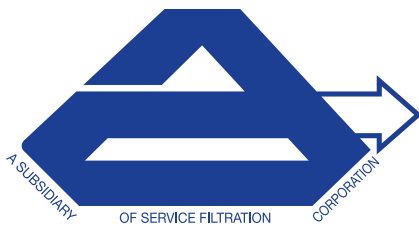

## RPA Series B300 Dimensional Data

### Standard Screens

Size Range	Opening	Gauge Thickness
2" - 8" (50mm - 200mm)	0.125 in. (3.2mm)	22
10" - 12" (250mm - 300mm)	0.125 in. (3.2mm)	16
14" - 16" (350mm - 400mm)	0.188 in. (4.8mm)	11

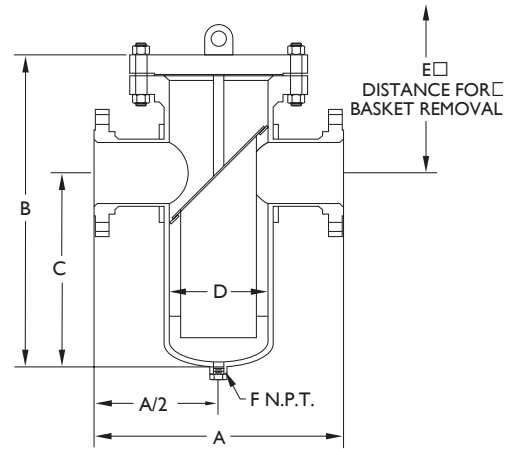

### Dimensional Data

Size in. (mm)	A in. (mm)	B in. (mm)	C in. (mm)	D in. (mm)	E in. (mm)	F in. (mm)	Weight Lb. (kg)	Cover Unit
2"	14.88	20.00	12.00	6.63	28.00	1/2	50	195
50	378	508	305	168	711	15	23	89
3"	16.50	25.00	15.75	8.63	34.25	3/4	81	250
80	419	635	400	219	870	20	37	114
4"	18.63	26.00	15.88	8.63	36.13	1	81	300
100	473	660	403	219	918	25	37	136
5"	20.25	28.00	17.13	10.75	38.88	1	125	400
125	514	711	435	273	987	25	57	182
6"	24.50	30.75	19.13	10.75	42.38	1	125	480
150	622	781	486	273	1076	25	57	218
8"	24.88	35.50	22.00	12.75	55.75	1 1/2	185	681
200	632	902	559	324	1416	40	84	310
10"	35.38	42.50	27.25	16.00	57.25	1 1/2	295	1100
250	899	1080	692	406	1454	40	134	500
12"	39.38	47.75	30.38	18.00	65.12	1 1/2	395	1650
300	1000	1213	772	457	1654	40	179	750
14"	41.50	52.50	33.00	20.00	72.00	2	505	2600
350	1054	1334	838	508	1829	50	229	1182
16"	47.50	60.00	38.88	24.00	81.13	2	790	2750
400	1207	1524	988	610	2061	50	358	1250

- Notes:** 1. Vents and differentials are optional.  
2. Cover lifting lug standard on sizes 8" and larger.

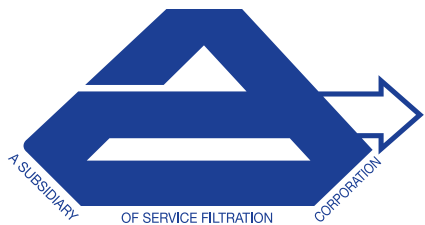

## RPA Series B600 Dimensional Data

### Standard Screens

Size Range	Opening	Gauge Thickness
2" - 8" (50mm - 200mm)	0.125 in. (3.2mm)	22
10" - 12" (250mm - 300mm)	0.125 in. (3.2mm)	16
14" - 16" (350mm - 400mm)	0.188 in. (4.8mm)	11

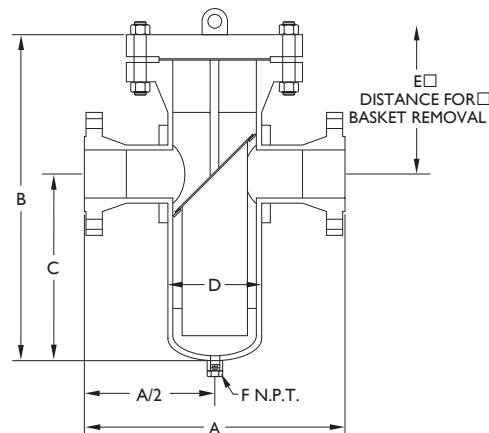

### Dimensional Data

Size in. (mm)	A in. (mm)	B in. (mm)	C in. (mm)	D in. (mm)	E in. (mm)	F in. (mm)	Weight Lb. (kg) Cover	Unit
2" 50	18.38 467	21.88 556	12.00 305	6.63 168	31.75 806	1/2 15	86 39	245 111
3" 80	23.88 606	26.50 673	15.75 400	8.63 219	37.25 946	3/4 20	140 64	360 164
4" 100	23.88 606	29.00 737	17.38 441	8.63 219	44.63 1133	1 25	140 64	400 182
5" 125	28.13 714	32.13 816	19.13 486	10.75 273	45.13 1146	1 25	230 105	750 341
6" 150	29.88 759	36.25 921	21.38 543	10.75 273	51.13 1299	1 25	230 105	825 375
8" 200	37.00 940	38.75 984	23.38 594	12.75 324	54.13 1375	1 1/2 40	295 134	1200 545
10" 250	42.50 1080	47.25 1200	27.25 692	16.00 406	68.25 1708	1 1/2 40	495 225	1600 727
12" 300	44.00 1118	53.25 1353	30.38 772	18.00 457	76.13 1934	1 1/2 40	630 286	1800 818
14" 350	46.00 1168	60.00 1524	35.13 892	20.00 508	84.88 2156	2 50	810 367	3000 1364
16" 400	54.00 1372	70.00 1778	42.25 1073	24.00 610	97.75 2483	2 50	1250 567	3200 1455

**Notes:** 1. Vents and differentials are optional.

2. Cover lifting lug standard on sizes 6" and larger.

**General:**

1. For further optional features see pages 21-22.

2. Other perforations and screen materials available. Please see page 24.

3. For pressure loss information see page 25.

4. For ordering information please see page 38.

5. Dimensions shown are subject to change.

Contact factory for certified prints when required.

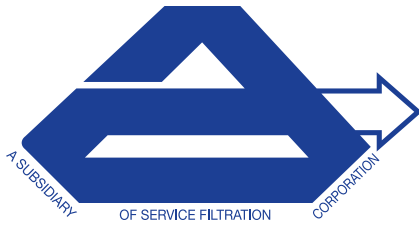

# RPA Series DBI25 Duplex Strainers

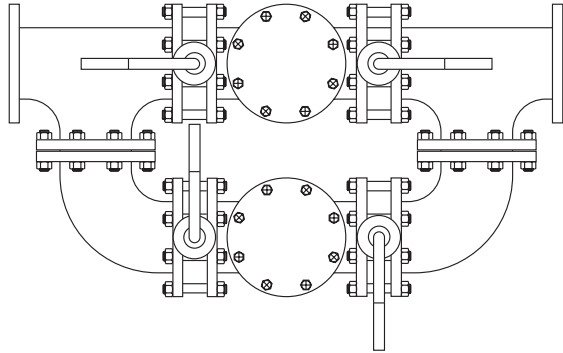

## Design Features:

- Inlet/outlet connections are FF flanged in accordance ASME B16.1.
- Four individual operated butterfly valves (RPA series BII25W/L) are used to divert and isolate flow.
- 304 SS perforated screens are standard.
- Cast components.
- Quick opening clamp covers (MAWP 50 psig) are optional.
- Drain connections furnished with plug as standard.
- Inexpensive construction and quick delivery.

## Parts List and Standard Materials

Part	Description	Specifications
Basket Strainers x 2	RPA Model BI25FIBI or BI25FICI Screen 1: Cover Gasket 1:	ASTM A126-B Type 304 SS Graphite
Butterfly Valves x 4	RPA Series BII25W/L Seat: Disc:	ASTM A126-B EPDM or Buna-N 316 SS, Bronze or Ductile Iron.
Flanged Fittings x 4	Cast Iron	ASTM A126-B
Hardware:	Carbon Steel	ASTM A193-B7, A194-2H
Gaskets	Rubber	

- Notes:**
1. Recommended Spares.
  2. Consult the RPA "Simplex Basket Strainer" and "Butterfly Valve" brochures for detailed information on these items.

## Upper Pressure Limits (Non-Shock)

Size	M.A.W.P.
5" - 12" (125mm - 300mm)	200 psig.

## Upper Pressure Limits (Non-Shock)

Body Material	Lower Limit $^{\circ}\text{F}$ ( $^{\circ}\text{C}$ )
A126-B	-20 (-28.9)

## Upper Pressure Limits (Non-Shock)

Substance	Upper Limit
Fluids	30 Ft/s (10 m/s)
Gases	200 Ft/s (65 m/s)

**Notes:** For greater velocities consult factory.

## RPA Series DBI25 Pressure Temperature Chart (Using RPABII25W/L ButterflyValves)

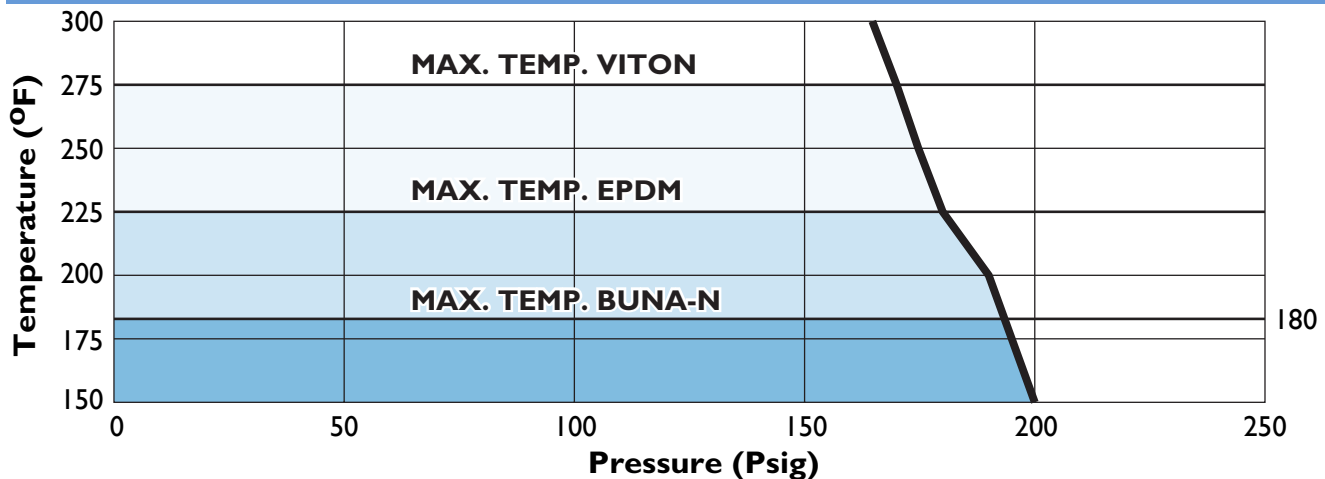



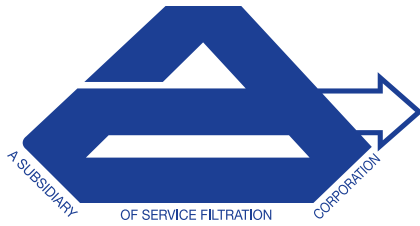

## RPA Series DBI 25 Duplex Strainers

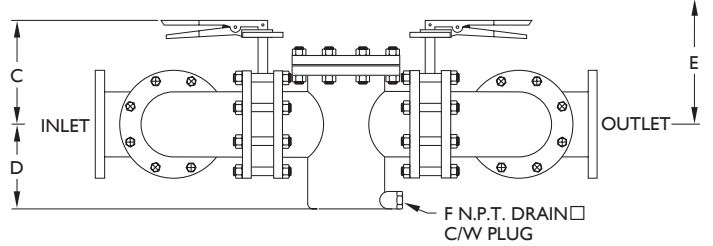
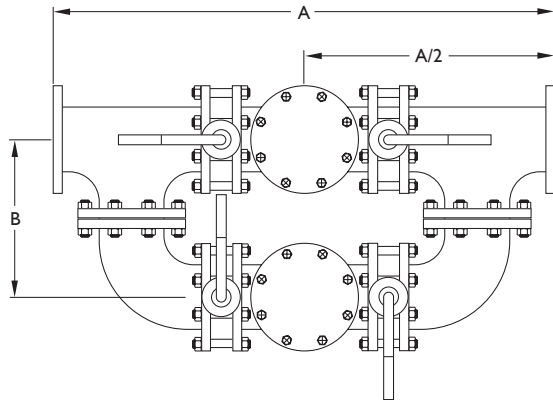

### Standard Screens

Size Range	Opening	Gauge Thickness
5" - 8" (125mm - 200mm)	0.125 in. (3.2mm)	22
10" - 12" (250mm - 300mm)	0.125 in. (3.2mm)	16

### Dimensional Data

Size in. (mm)	A in. (mm)	B in. (mm)	C in. (mm)	D in. (mm)	E in. (mm)	F NPT in. (mm)	Weight Lb. (kg.) Cover	Unit
5" 125	47.38 1203	15.13 384	6.63 168	8.00 203	21.25 540	1 25	20 9	725 329
6" 150	51.00 1295	16.13 410	7.00 178	8.62 219	22.62 575	1 25	26 12	800 363
8" 200	61.00 1549	18.13 461	9.25 235	11.75 298	30.25 768	1½ 40	45 20	1400 636
10" 250	69.25 1759	22.13 562	10.75 273	13.75 349	35.25 895	1½ 40	70 32	1850 840
12" 300	79.25 2013	24.13 613	13.38 340	16.38 416	43.13 1096	2 50	110 50	3300 1497

- Notes:**
1. Strainers may be supplied with 50 psig clamped covers. Please contact factory.
  2. Vents and differential connections are optional.

**General:**

1. For further optional features see pages 21-22.
2. Other perforations and screen materials available. Please see page 24.
3. For pressure loss information see page 25.
4. For ordering information please see page 38.
5. Dimensions shown are subject to change. Contact factory for certified prints when required.

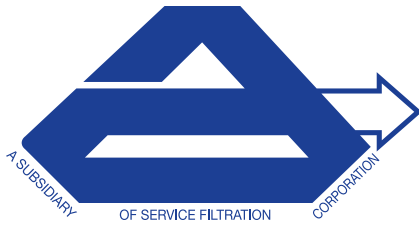

# RPA Series DBI50 Duplex Strainers

## Design Features:

- Standard sizes from 6" - 24".
- Available with RF or RTJ flanged (ASME B16.5) or Buttweld (ASME B16.9) end connections.
- Standard thru bolt cover design.
- Custom modifications are available.
- May be installed in horizontal pipelines.
- All welders qualified to ASME Section IX.
- Strainers designed to meet the requirements of ASME B31.1, ASME B31.3 and/or ASME Section VIII, Div. I.
- Four individual operated butterfly valves (RPA series BI125W/L) are used to divert and isolate flow. Ball, gate and other isolation valve types may be used if requested.
- 304 SS perforated screens are standard.
- Drains and differential connections are standard and are furnished with plug.
- Vents and special covers are optional (See pages 21-22).

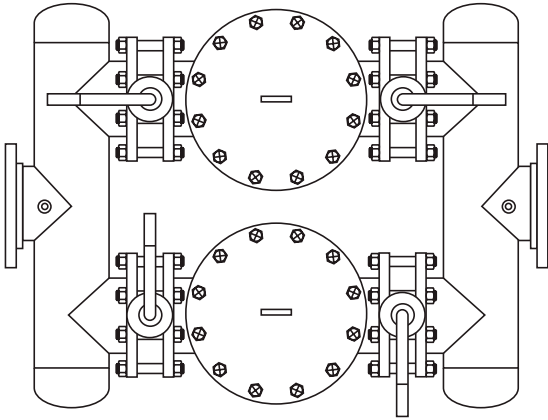

## Parts List and Standard Materials

Part	Description	Specifications	
		Carbon Steel	Stainless Steel <sup>1</sup>
Basket Strainers x 2	RPA Series BI150 <sup>2</sup> Screen <sup>3</sup> : Cover Gasket <sup>3</sup> :	Fabricated Carbon Steel Type 304 SS 304 SS Spiral Wound	Fabricated Stainless Steel Type 304 SS 304 SS Spiral Wound
Butterfly Valves x 4	RPA Series BI125W/L <sup>4</sup> Seat: Disc:	ASTM A126-B <sup>5</sup> EPDM or Buna-N 316 SS, Bronze or Ductile Iron.	ASTM A126-B <sup>5</sup> EPDM or Buna-N 316 SS, Bronze or Ductile Iron.
Manifolds x 2	Pipe Flanges Couplings / Threadolets	A53 E/B, A106-B A105 A105	A312 A182 A182
Hardware:	Studs Nuts	A193-B7 A194-2H	A193-B8-1 A194-8
Gaskets		304 SS Spiral Wound	304 SS Spiral Wound

- Notes:** 1. 304 SS strainers use 304 grade material, 316 SS strainers use 316 grade material, etc.  
 2. See page 13 for detailed information.  
 3. Recommended Spares.  
 4. Consult the RPA "Butterfly Valve" brochure for detailed information.  
 5. Non-wetted.  
 6. For strainers designed to ASME Section VIII, Div. I the "A" designation becomes "SA".

## RPA Series DBI50 Pressure Temperature Chart (Using RPA BI125W/L Butterfly Valves)

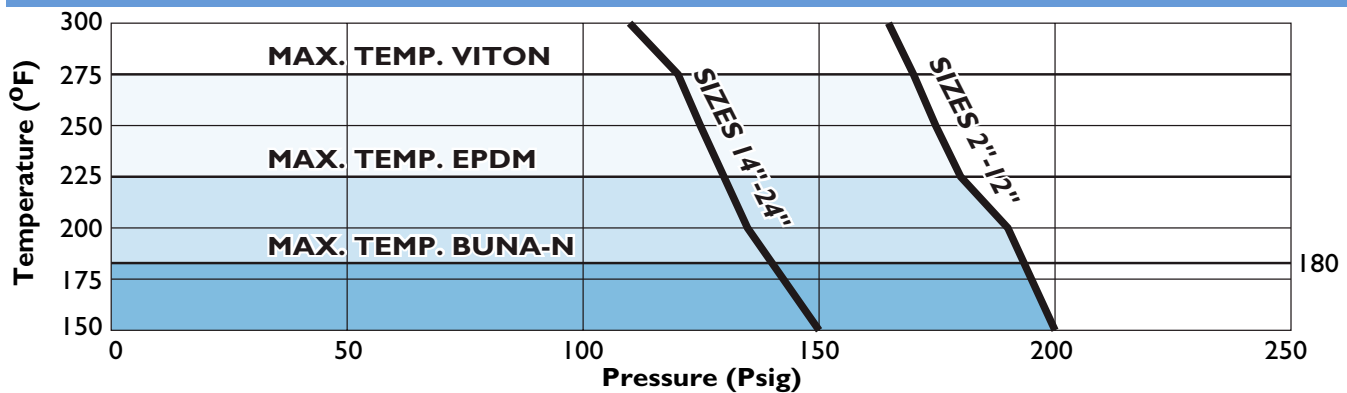

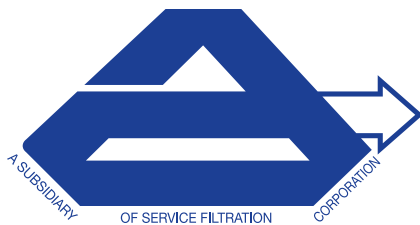

# RPA Series DBI50 - Style I Duplex Strainers

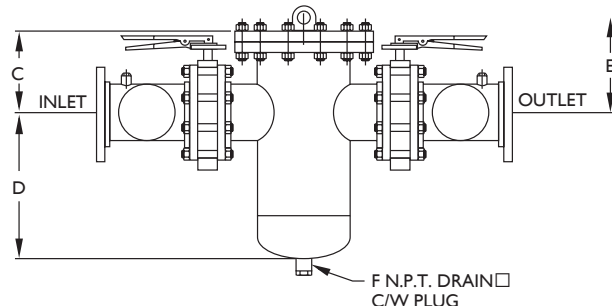
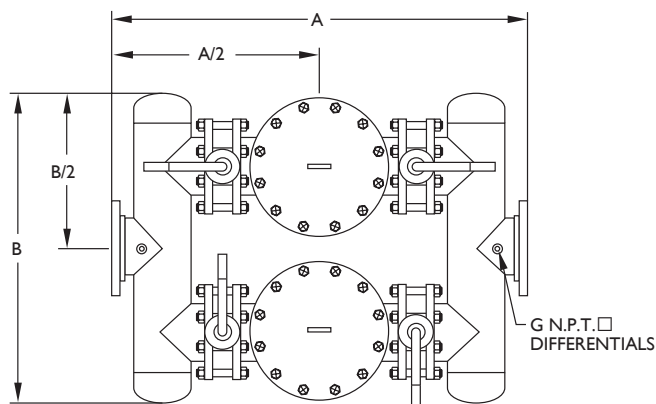

## Standard Screens

Size Range	Opening	Gauge Thickness
2" - 8" (50mm - 200mm)	0.125 in. (3.2mm)	22
10" - 12" (250mm - 300mm)	0.125 in. (3.2mm)	16
14" - 24" (350mm - 600mm)	0.188 in. (4.8mm)	11

## Dimensional Data (Style I)

Size <sup>1</sup> in. (mm)	A in. (mm)	B in. (mm)	C in. (mm)	D in. (mm)	E in. (mm)	F NPT in. (mm)	G NPT in. (mm)	Weight Lb. (kg.) Cover	Unit
2" 50	32.00 813	20.00 508	6.00 152	11.00 279	25.00 635	3/4 20	1/2 15	26 12	280 127
3" 80	38.00 965	24.00 610	8.00 203	14.00 356	29.00 737	1 25	1/2 15	45 20	300 136
4" 100	38.00 965	26.00 660	8.00 203	14.00 356	31.00 787	1 25	1/2 15	45 20	450 204
6" 150	48.00 1219	36.00 914	10.00 254	17.00 432	36.00 914	1 25	1/2 15	70 32	700 318
8" 200	57.00 1448	43.00 1092	12.00 305	21.00 533	43.00 1092	1 25	1/2 15	110 50	1400 636
10" 250	76.00 1930	55.00 1397	13.00 330	25.00 635	58.00 1473	1 1/2 40	1/2 15	180 82	1850 840
12" 300	85.00 2159	57.00 1448	14.00 356	28.00 711	62.00 1575	1 1/2 40	1/2 15	220 100	2750 1249
14" 350	92.00 2337	60.00 1524	18.00 457	33.00 838	65.00 1651	2 50	1/2 15	285 129	4000 1816
16" 400	104.00 2642	64.00 1626	20.00 508	36.00 914	72.00 1829	2 50	3/4 20	430 195	5300 2406
18" 450	116.00 2946	82.00 2083	20.00 508	40.00 1016	80.00 2032	2 50	3/4 20	430 195	5900 2679
20" 500	120.00 3048	87.00 2210	24.00 610	46.00 1168	90.00 2286	2 50	3/4 20	965 438	8000 3632
24" 600	132.00 3353	94.00 2388	28.00 711	40.00 1016	110.00 2794	2 50	3/4 20	1540 699	9000 4086

**Notes:** 1. Other sizes available. Consult factory.

2. Dimensions can be modified to suit the customers requirements. Please consult factory.
3. Legs and other supports are available.
4. Vents are optional.

**General:**

1. For further optional features see pages 21-22.
2. Other perforations and screen materials available. Please see page 24.

3. For pressure loss information see page 25.
4. For ordering information please see page 38.
5. Dimensions shown are subject to change. Contact factory for certified prints when required.

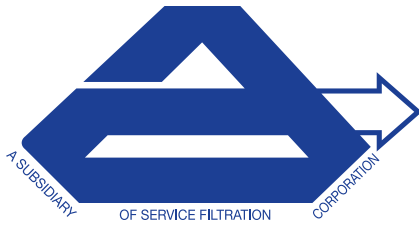

# RPA Series DBI50 - Style 2 Duplex Strainers

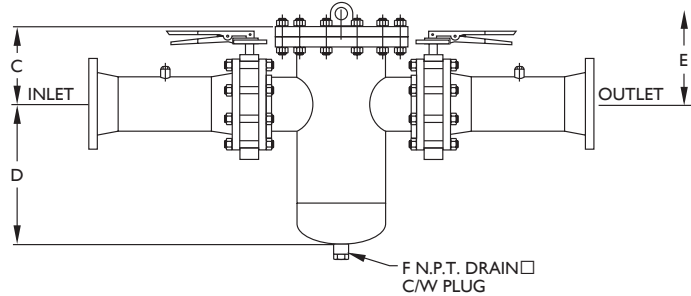
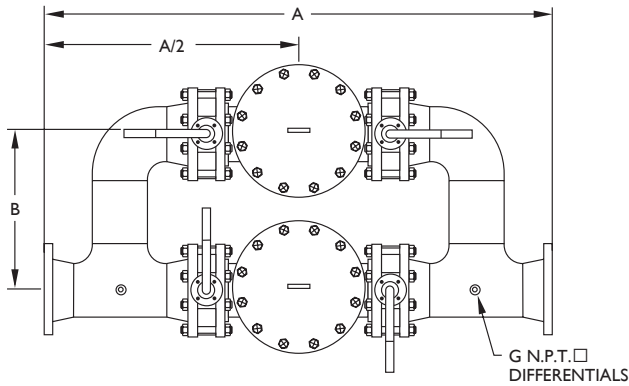

## Standard Screens

Size Range	Opening	Gauge Thickness
2" - 8" (50mm - 200mm)	0.125 in. (3.2mm)	22
10" - 12" (250mm - 300mm)	0.125 in. (3.2mm)	16
14" - 24" (350mm - 600mm)	0.188 in. (4.8mm)	11

## Dimensional Data (Style 2)

Size <sup>1</sup> in. (mm)	A in. (mm)	B in. (mm)	C in. (mm)	D in. (mm)	E in. (mm)	F NPT in. (mm)	G NPT in. (mm)	Weight Lb. (kg.) Cover Unit
2" 50	36.00 914	13.00 330	6.00 152	11.00 279	25.00 635	3/4 20	1/2 15	26 12 280 127
3" 80	42.00 1067	16.00 406	8.00 203	14.00 356	29.00 737	1 25	1/2 15	45 20 300 136
4" 100	49.00 1245	16.00 406	8.00 203	14.00 356	31.00 787	1 25	1/2 15	45 20 450 204
6" 150	62.00 1575	18.00 457	10.00 254	17.00 432	36.00 914	1 25	1/2 15	70 32 700 318
8" 200	74.00 1880	22.00 559	12.00 305	21.00 533	43.00 1092	1 25	1/2 15	110 50 1400 636
10" 250	92.00 2337	28.00 711	13.00 330	25.00 635	58.00 1473	1 1/2 40	1/2 15	180 82 1850 840
12" 300	104.00 2642	24.00 610	14.00 356	28.00 711	62.00 1575	1 1/2 40	1/2 15	220 100 2750 1249
14" 350	114.00 2896	32.00 813	18.00 457	33.00 838	65.00 1651	2 50	1/2 15	285 129 4000 1816
16" 400	126.00 3200	32.00 813	20.00 508	36.00 914	72.00 1829	2 50	3/4 20	430 195 5300 2406
18" 450	140.00 3556	40.00 1016	20.00 508	40.00 1016	80.00 2032	2 50	3/4 20	430 195 5900 2679
20" 500	156.00 3962	40.00 1016	24.00 610	46.00 1168	90.00 2286	2 50	3/4 20	965 438 8000 3632
24" 600	182.00 4623	48.00 1219	28.00 711	40.00 1016	110.00 2794	2 50	3/4 20	1540 699 9000 4086

- Notes:**
- Other sizes available. Consult factory.
  - Dimensions can be modified to suit the customers requirements. Please consult factory.
  - Legs and other supports are available. Please contact factory.
  - Vents are optional.

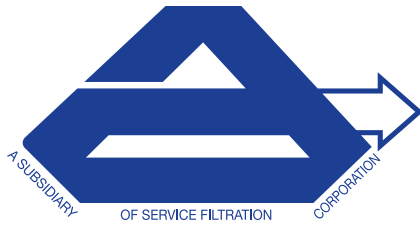

# RPA Series DBI50 - Style 3 Duplex Strainers

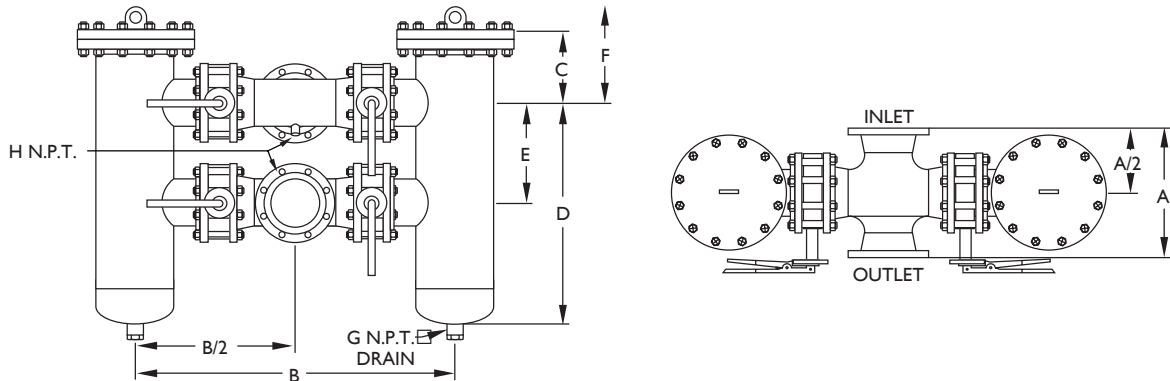

## Standard Screens

Size Range	Opening	Gauge Thickness
2" - 8" (50mm - 200mm)	0.125 in. (3.2mm)	22
10" - 12" (250mm - 300mm)	0.125 in. (3.2mm)	16
14" - 24" (350mm - 600mm)	0.188 in. (4.8mm)	11

## Dimensional Data (Style 3)

Size <sup>1</sup> in (mm)	A in (mm)	B in (mm)	C in (mm)	D in (mm)	E in (mm)	F in (mm)	G NPT in (mm)	H NPT in (mm)	Weight Lb. (kg.) Cover Unit
2"	10.00	26.00	6.00	20.00	14.00	32.00	3/4	1/2	26 280
50	254	660	152	508	356	813	20	15	12 127
3"	12.25	30.00	8.00	22.50	14.50	38.50	1	1/2	45 300
80	311	762	203	572	368	978	25	15	20 136
4"	14.25	36.00	8.00	25.50	17.50	41.50	1	1/2	45 450
100	362	914	203	648	445	1054	25	15	20 204
6"	18.25	44.00	10.00	31.00	21.00	51.00	1	1/2	70 700
150	464	1118	254	787	533	1295	25	15	32 318
8"	22.00	50.00	12.00	35.00	23.00	59.00	1	1/2	110 1400
200	559	1270	305	889	584	1499	25	15	50 636
10"	25.00	64.00	13.00	39.00	28.00	65.00	1 1/2	1/2	180 1850
250	635	1626	330	991	660	1651	40	15	82 840
12"	29.00	72.00	14.00	48.00	30.00	72.00	1 1/2	1/2	220 2750
300	737	1829	356	1219	762	1829	40	15	100 1249
14"	32.00	76.00	18.00	50.00	32.00	86.00	2	1/2	285 4000
350	813	1930	457	1270	813	2184	50	15	129 1816
16"	34.00	84.00	20.00	54.00	34.00	94.00	2	3/4	430 5300
400	864	2134	508	1372	864	2388	50	20	195 2406
18"	38.00	94.00	20.00	56.00	36.00	96.00	2	3/4	430 5900
450	965	2388	508	1422	914	2438	50	20	195 2679
20"	41.38	104.00	24.00	64.00	40.00	112.00	2	3/4	965 8000
500	1051	2642	610	1626	1016	2845	50	20	438 3632
24"	46.00	122.00	28.00	76.00	48.00	132.00	2	3/4	1540 9000
600	1168	3099	711	1930	1219	3353	50	20	699 4086

**Notes:** 1. Other sizes available. Consult factory.

2. Dimensions can be modified to suit the customers requirements. Please consult factory.
3. Legs and other supports are available.
4. Vents are optional.

**General:**

1. For further optional features see pages 21-22.
2. Other perforations and screen materials available. Please see page 24.

3. For pressure loss information see page 25.
4. For ordering information please see page 38.
5. Dimensions shown are subject to change. Contact factory for certified prints when required.

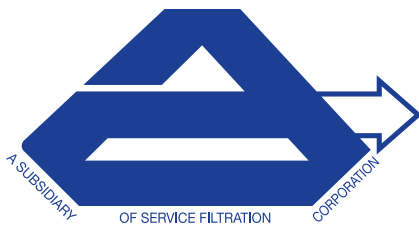

## Quick Opening Covers and Cover Removal Aids

The quick opening covers and cover removal aids available on RPA fabricated strainers are distinguished by their compact size and functional design. Materials of construction are in accordance with ASME specifications and manufacturing complies with the applicable rules of the ASME Code for Pressure Piping and with the ASME Boiler and Pressure Vessel Code.

### Cover Type BD — Davit Assembly

The Davit assembly is used to enable the user to swing the cover away from the strainer in order to facilitate basket or screen removal for cleaning. It's primary use is for larger sized strainers where cover removal is difficult. The davit assembly is an inexpensive alternative to quick release covers, especially when operating conditions require a bolted cover to be utilized.

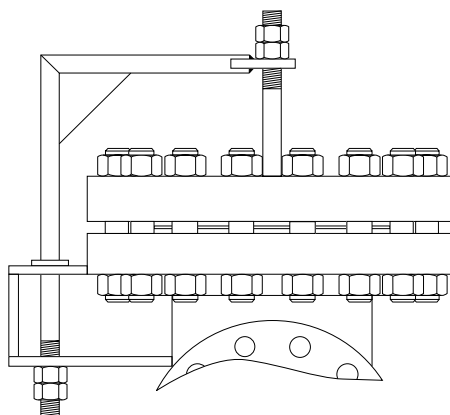

### Cover Type H — T-Bolt Hinged Cover

The T-bolt hinged cover is used for nominal pressure applications while being the most inexpensive closure available on RPA fabricated strainers. The T-bolt hinged cover is opened quickly and easily using an O-Ring as a seal. The operator merely loosens the T-bolts until they clear the holding lugs and allow the head to be swung open on it's hinge. Camlock and Break-over Wrench assemblies are also available that eliminate the need for a wrench.

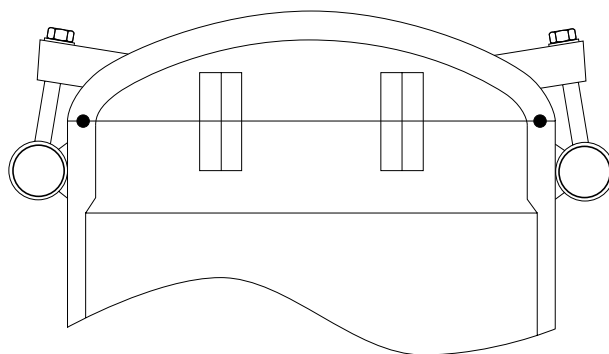

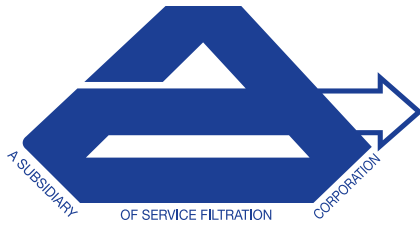

## Quick Opening Covers and Cover Removal Aids

### Cover Type Y — Yoke Hinged Cover

The yoke hinged closure is a true ANSI rated closure. Used primarily on high pressure applications, yoke hinged covers are available with 150%, 300%, 600%, 900%, and 1500% ANSI ratings. Yoke hinged covers available on RPA fabricated strainers are available with a wide range of operating aids ranging from single-lever chain and sprocket drives to completely automated types. O-rings are utilized as the sealing member.

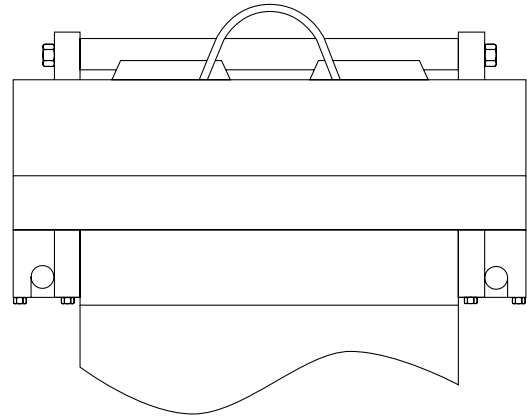

### Cover Type T — Quick Opening Threaded Cover

The threaded cover closure consists of a cap which fastens to a hub that has been welded to the strainer body. The female cap is threaded onto the male hub and an O-Ring is utilized to make the seal. The placement of this O-Ring prevents corrosion of the closure threads allowing for long, trouble free service. The threaded closure can be utilized on both nominal and high pressure applications.

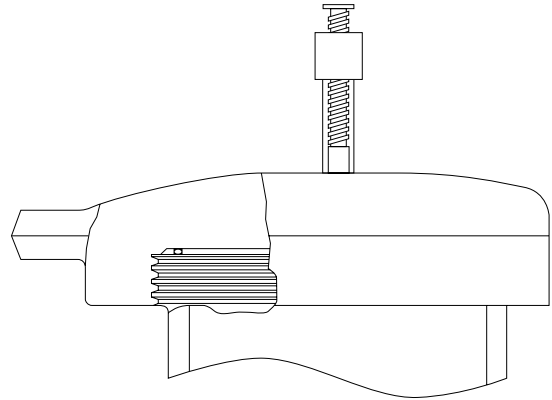

### General Comparison of Different Closure Types

Comparison Item	Closure Type				
	Bolted Type B	Bolted with davit Type BD	Swing Bolt Hinged Type H	Yoke Type Y	Threaded Type T
Cost (Ranking 1 = Least Expensive)	1	2	3	4	4
Quick Opening Ability (Ranking 1 = Quickest)	5	4	3	1	1
Low Pressure Applications (Recommended Closures)	X	X	X		
Nominal Pressure Applications (Recommended Closures)	X	X	X	X	X
High Pressure Applications (Recommended Closures)	X	X		X	X

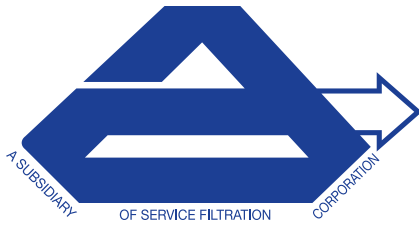

# Replacement Baskets

## Design Features:

RPA design's and manufactures baskets for all makes of basket and duplex strainers. The range of materials and size of units is unlimited.

RPA is able to provide baskets manufactured from:

- Perforated Plate
- Mesh or Mesh/Perf. combination
- Wedge Wire
- Electron Beam Small Hole Perforated Plate

Using the above processes or combination thereof, RPA can provide screens and baskets suitable for a wide range of applications.

## Screen/Basket Checklist

Kindly photocopy this page and fill out the pertinent information.

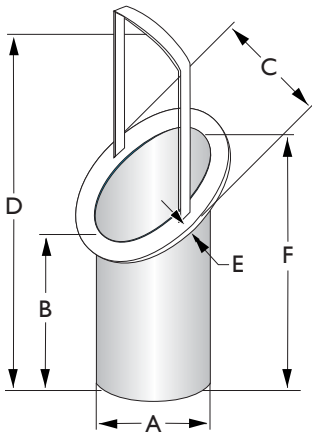

**BASKET STRAINER**  
STYLE "1"

### Performance Requirements

Description	Customers Requirement
Required Level of Filtration	_____
Material of Construction	_____
Minimum Specified Burst Pressure	_____
Flow Direction	_____
Other	_____

### Dimensional Requirements

Description	Customers Requirement
Basket Style	(1 or 2)
Basket Outer Diameter	A
Basket Height	B
Ring OD	C
Overall Height	D
Ring Thickness	E
Basket Long Height	F

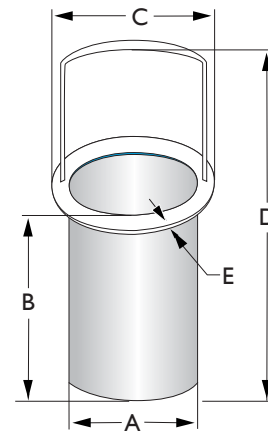

**BASKET STRAINER**  
STYLE "2"



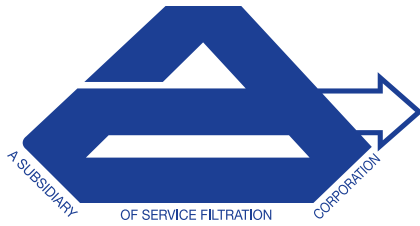

## Factors To Consider

### Purpose

If the basket strainer is being used for protection rather than direct filtration, RPA's standard screens will suffice in most applications.

### Service

With services that require extremely sturdy screens, such as high pressure/ temperature applications or services with high viscosities, RPA recommends that perforated screens without mesh liners be used. If mesh is required to obtain a certain level of filtration, then RPA recommends a trapped perf./ mesh/perf. combination.

### Filtration Level

When choosing a perf. or a mesh/perf. combination attention should be given to ensure overstraining does not occur. As a general rule the specified level of filtration should be no smaller than half the size of the particle to be removed. If too fine a filtration is specified the pressure drop through the strainer will increase very rapidly, possibly causing damage to the basket.

## Screen Types/Dimensions

1/4" Dia. - 40% O.A.	3/16" Dia. - 50% O.A.	5/32" Dia. - 58% O.A.	1/8" Dia. - 40% O.A.	3/32" Dia. - 39% O.A.	1/16" Dia. - 37% O.A.	3/64" Dia. - 36% O.A.	1/32" Dia. - 40% O.A.	0.027" Dia. - 23% O.A.	20 Mesh - 49% O.A. 0.035" Openings	30 Mesh - 45% O.A. 0.022" Openings	40 Mesh - 41% O.A. 0.016" Openings	60 Mesh - 38% O.A. 0.010" Openings	80 Mesh - 36% O.A. 0.008" Openings	100 Mesh - 30% O.A. 0.006" Openings

- Notes:**
1. Screen openings other than those shown above are readily available. RPA inventories various mesh sizes as fine as 5 micron and perforated plate as coarse as 1/2" Dia.
  2. Screens are available in a wide range of materials. RPA inventories various screen material in Carbon Steel, Stainless Steel (304, 316), Alloy 20, Monel 400, Hastalloy C and Titanium Grade 2.
  3. Custom manufactured screens are available upon request. Please consult factory.

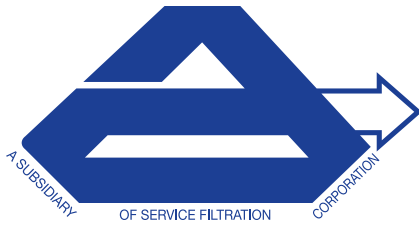

# Engineering Data Temporary Strainer Pressure Drop— Liquids

## Temporary Strainer Pressure Drop — Liquids (Sizes $\frac{3}{4}$ - 5 )

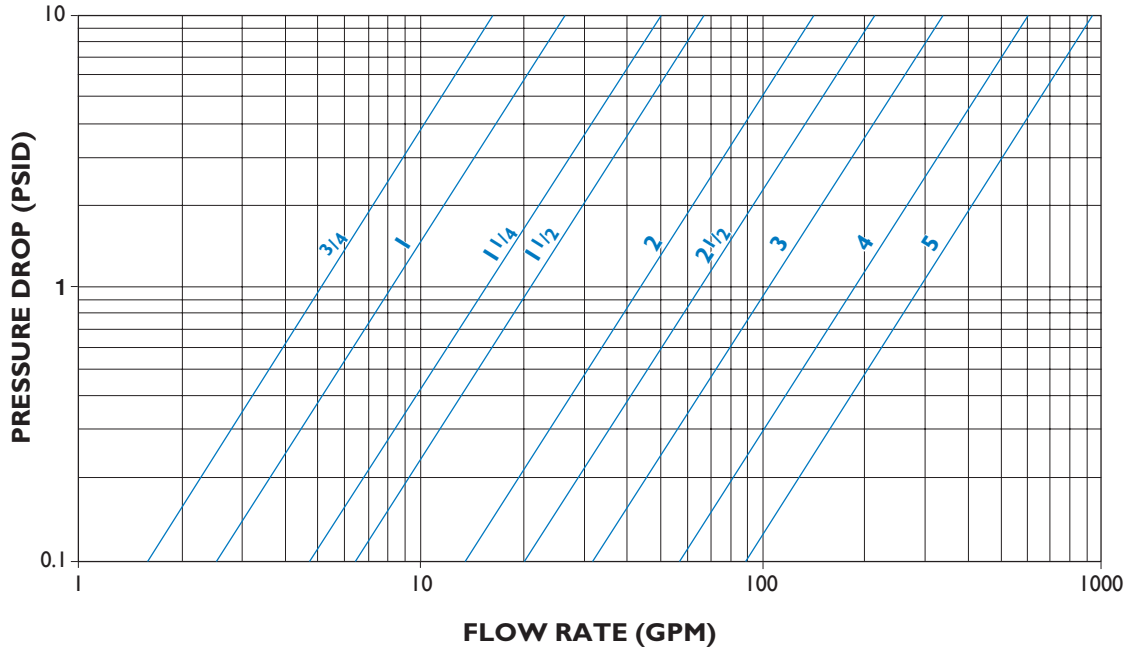

FIGURE 1

## Temporary Strainer Pressure Drop — Liquids (Sizes 6 - 48 )

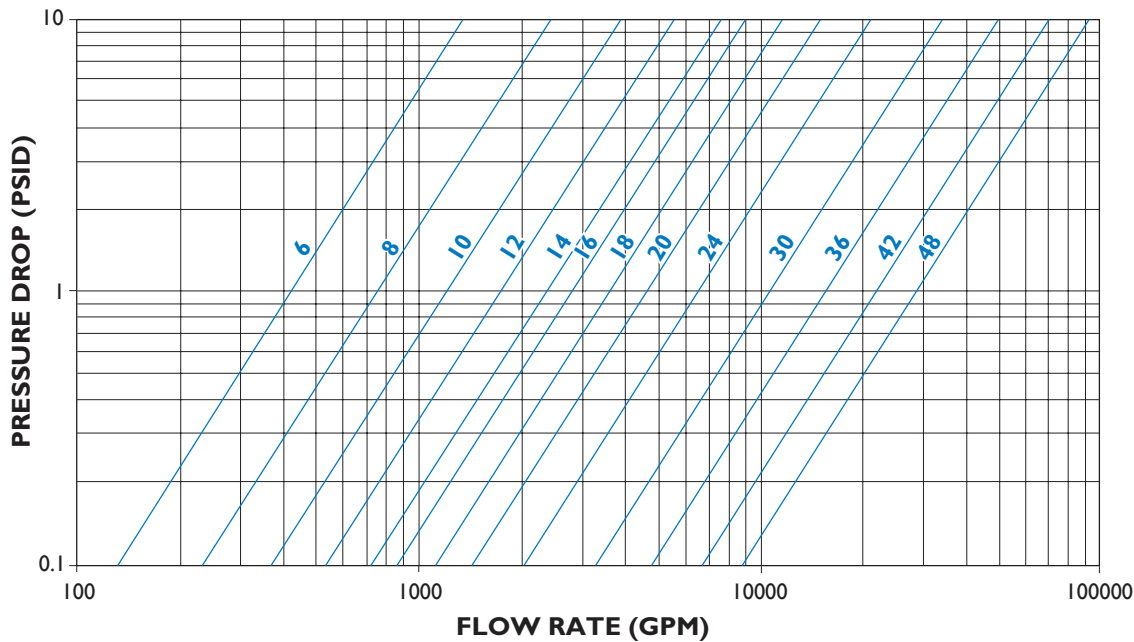
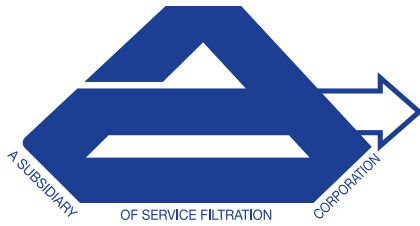

FIGURE 2

**Notes:** 1. Pressure drop curves are based on water flow with standard screens.  
See page 28 for correction factors to be used with other fluids and/or screen openings.



# Engineering Data Fabricated Y and Tee Strainer Pressure Drop — Liquids

## Fabricated Y-Strainer Pressure Drop — Liquids (Sizes 2 - 24 )

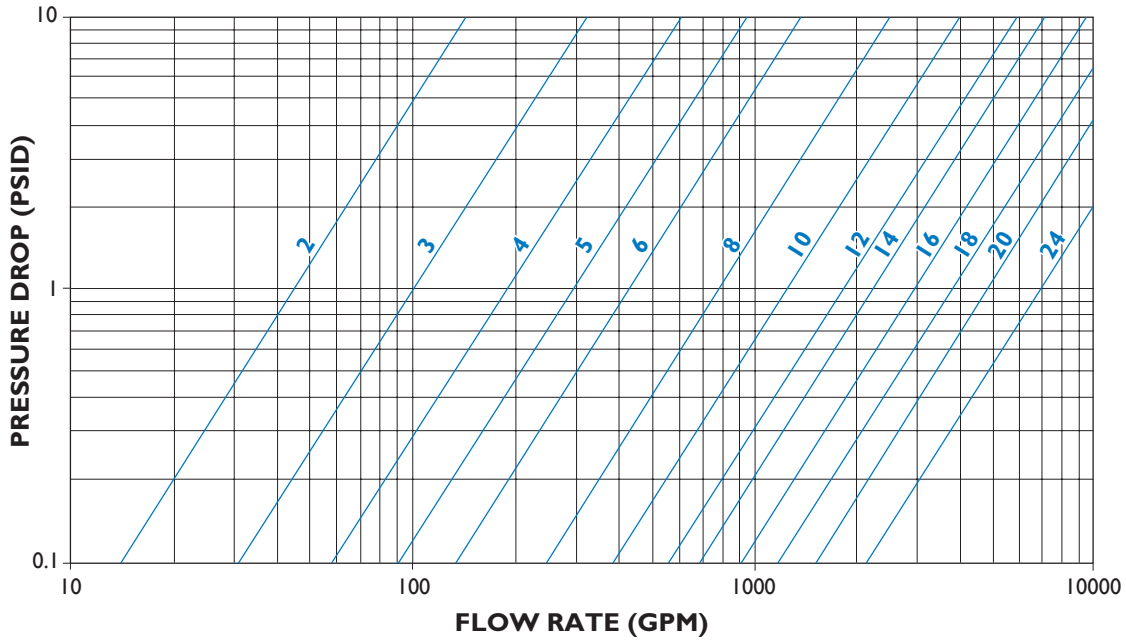

## Tee Strainer Pressure Drop — Liquids (Sizes 2 - 24 )

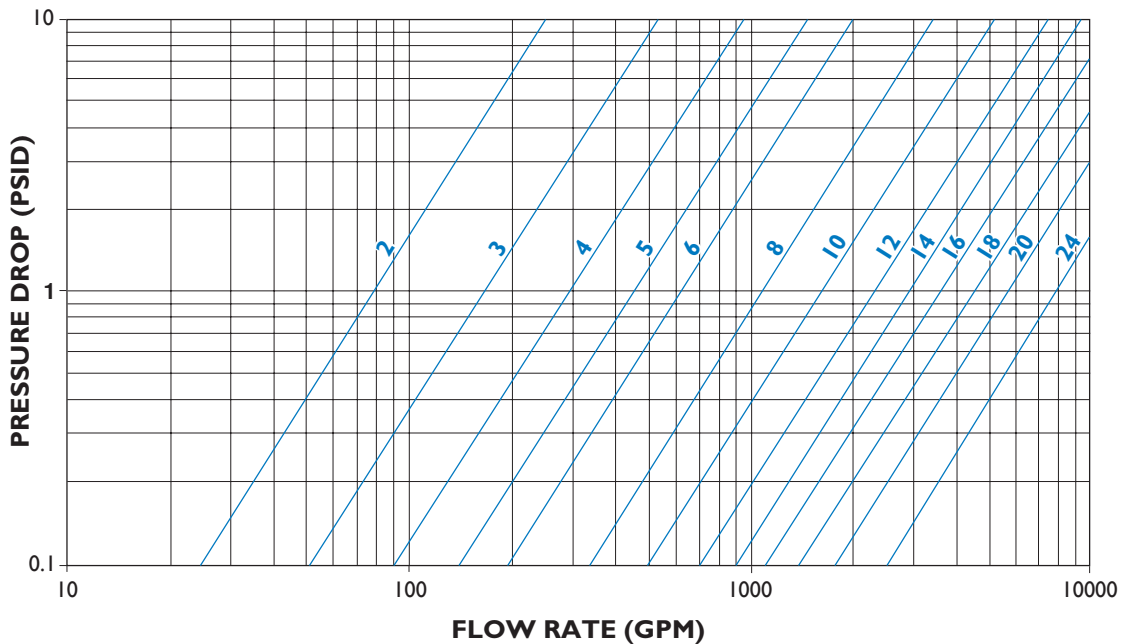

**Notes:** 1. Pressure drop curves are based on water flow with standard screens.  
See page 28 for correction factors to be used with other fluids and/or screen openings.

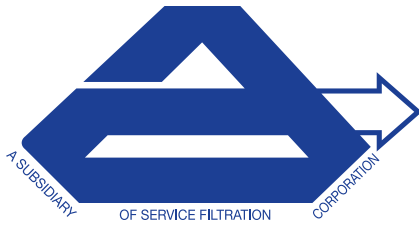

# Engineering Data Fabricated Basket and Duplex Strainer Pressure Drop — Liquids

## Fabricated Basket Strainer Pressure Drop — Liquids (Sizes 2 - 24 )

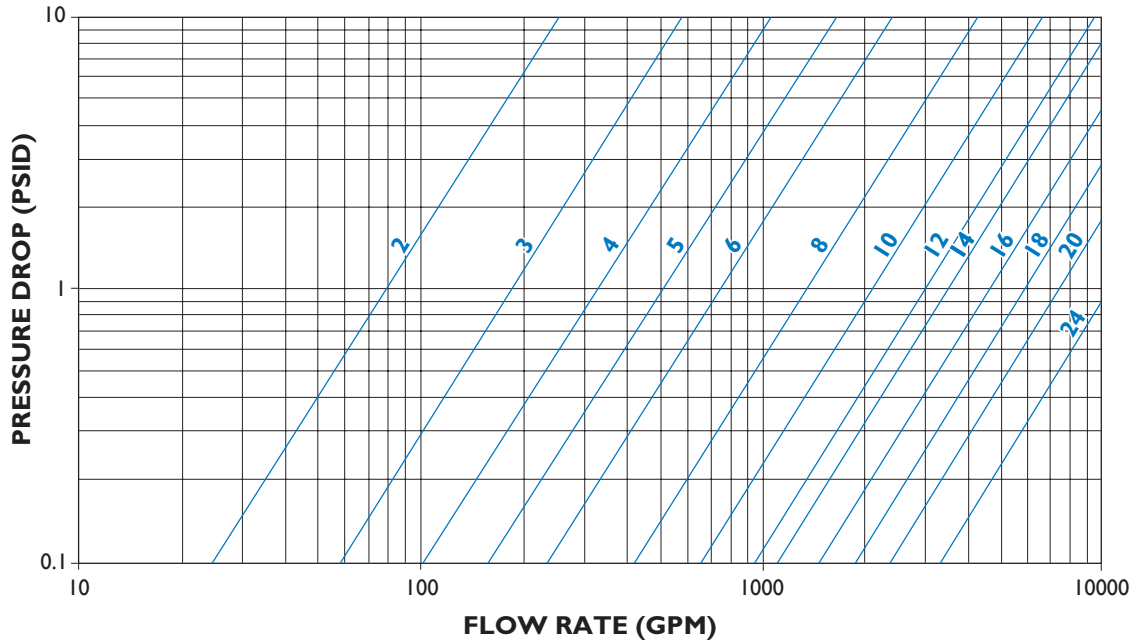

FIGURE 5

## Fabricated Duplex Strainer Pressure Drop — Liquids (Sizes 5 - 24 )

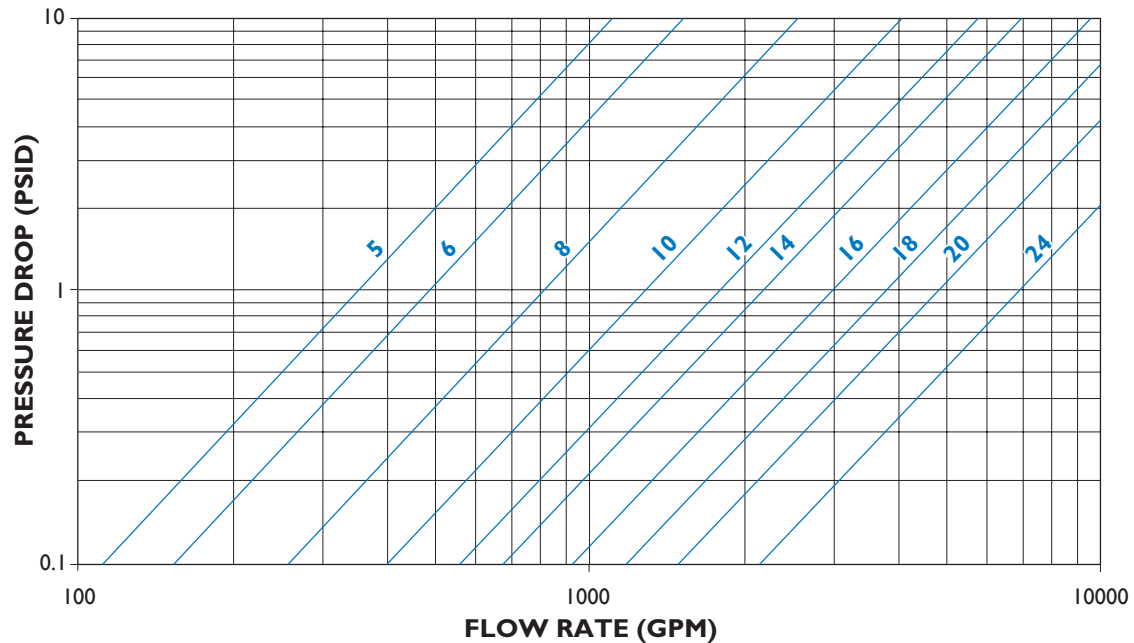
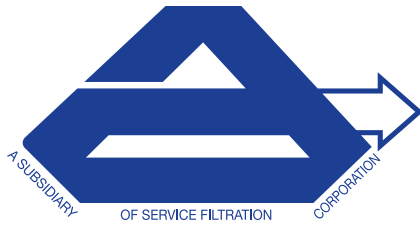

FIGURE 6

**Notes:** 1. Pressure drop curves are based on water flow with standard screens.  
See page 28 for correction factors to be used with other fluids and/or screen openings.



## Screen Correction Factor Chart (For Non-Standard and Mesh Lined Screens)

\*Multiply values obtained from figure 1 thru 6 by the appropriate values shown below

**Chart #1**

Size Range	SCREEN OPENINGS							
	Perforated Plate % Screen Material Open Area					Mesh lined standard screens % Screen Material Open Area		
	60%	50%	40%	30%	20%	50%	40%	30%
1/4" - 1 1/2"	0.45	0.55	0.7	1	1.15	1.05	1.05	1.2
2" - 48"	0.65	0.8	1	1.4	2.15	1.05	1.05	1.2

**Notes:** 1. See page 24 for % Open Areas of RPA inventoried perforated plate.

2. Standard screens for sizes 3/4" to 1 1/2" is approximately a 30% open area screen media.

3. Standard screens for sizes 2" and larger is approximately a 40% open area screen media.

### Example:

**Strainer Size:** 10"  
**RPA Model:** B150FSBWI  
**Filtration:** 100 Mesh lined 1/8" Perf.  
**Flow rate:** 3000 GPM  
**Service:** Water

- A)** Using figure 5 the pressure drop is determined to be 2.0 psid with RPA's standard screen.
- B)** Looking at page 26 we find that the % Open area of 100 mesh is 30%.
- C)** Using chart 1 we read the correction factor to be 1.2 for 100 mesh lined 1/8" perf.
- D)** Total pressure drop equals  $2.0 \times 1.2 = 2.4$  psid clean.

## Viscosity and Density Correction Factor Chart

Size Range	Component Factor (CF)	Viscosity Cp	Body Loss Factor (BF)	Screen Loss Factor			
				Perf alone (PF)	20 Mesh Lined (MF)	30, 40, Mesh Lined (MF)	60 to 300 Mesh Lined (MF)
3/4" - 1 1/2"	0.25	10	1	1.15	1.3	1.4	1.5
2" - 48"	0.35	25	1.2	1.25	2	2.2	2.5
		100	1.6	1.4	3	4	6.5
		200	2.2	1.5	4.5	7	11.5
		500	4.4	1.6	10	15	25
		1000	8	1.7	15	30	50
		2000	15.2	1.9	30	60	100

### How to Use:

- 1) Determine the pressure drop (P1) through the strainer with water flow and standard screens.
- 2) If non-standard screens (i.e. 40 mesh, etc.) are being used, apply factors in Chart #1 to determine corrected pressure drop (P2).
- 3) Multiply P1 or P2 (if used) by the specific gravity of the fluid actually flowing through the strainer to get P3.
- 4) Using Chart #2 multiply P3 by the appropriate Component Factor (CF) to get P4.
- 5) Let  $P5 = P3 - P4$ .
- 6) Multiply P4 by the appropriate Body Loss Factor (BF) in Chart #3 to get P6.
- 7) Multiply P5 by the appropriate Screen Loss Factor (PF or MF) in Chart #3 to get P7.
- 8) Total pressure drop  $P8 = P6 + P7$ .

### Example:

**Strainer Size:** 10"  
**RPA Model:** B150FSBWI  
**Filtration:** 100 mesh lined 1/8" perf.  
**Flow rate:** 3000 GPM  
**Specific Gravity:** 1  
**Viscosity:** 100 cP

- A)** As shown in the above example, the corrected pressure drop (P2) = 2.4 psid
- B)** Since S.G. = 1,  $P3 = P2 = 2.4$  psid
- C)** Using Chart #2  $P4 = 0.35 \times P3 = 0.84$  psid
- D)**  $P5 = 2.4 - 0.84 = 1.56$  psid
- E)** Using Chart #3  $P6 = 0.84 \times 1.6 = 1.34$  psid
- F)** Again using Chart #3  $P7 = 1.56 \times 6.5 = 10.14$  psid
- G)** Total pressure drop  $P8 = 1.34 + 10.14 = 11.48$  psid clean

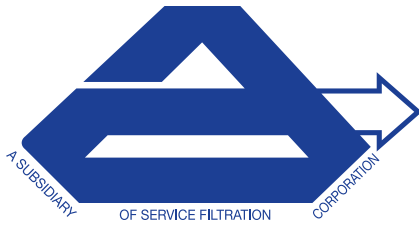

# Engineering Data Correction Factors For Clogged Screens

## Correction Factors For Clogged Screens

\* Multiply values obtained from figures 1 thru 6 by the appropriate values shown below

**Chart #4**

% Clogged	Ratio of Free Screen Area to Pipe Area						
	10:1	8:1	6:1	4:1	3:1	2:1	1:1
10%	-	-	-	-	-	-	3.15
20%	-	-	-	-	-	1.15	3.9
30%	-	-	-	-	-	1.4	5
40%	-	-	-	-	-	1.8	6.65
50%	-	-	-	-	1.25	2.5	9.45
60%	-	-	-	1.15	1.8	3.7	14.5
70%	-	-	-	1.75	2.95	6.4	26
80%	-	1.1	1.75	3.6	6.25	14	58
90%	2.3	3.45	6	13.5	24	55	-

- Notes:** 1. See page 35 for the ratio of free area to pipe area for RPA Strainers equipped with standard screens.  
2. For screens other than RPA's standard, use the following formula to calculate the ratio free area to pipe area:

$$R = \frac{A_g \times OA}{100A_p}$$

where;

- R = Ratio free area to pipe area  
 A<sub>g</sub> = Gross screen area, sq. in. (See page 35)  
 OA = Open area of screen media, % (See page 24, i.e. 1/8" perf. = 40%)  
 A<sub>p</sub> = Nominal area of pipe fitting, sq. in. (See page 35)

### Example #1

**Strainer Size:** 8"  
**RPA Model:** T150FSBW1  
**Filtration:** 1/8" Perf.  
**Flow rate:** 1000 GPM  
**Service:** Water  
**% Clogged:** 20%

- A)** Using Figure #4 the pressure drop is determined to be 0.9 psid with RPA's standard screen.  
**B)** Looking at page 35 ratio of free area to pipe area for a 8" RPA series T strainer is equal to 1.3:1 (1:1 approx.).  
**C)** Using Chart #4 we read the correction factor to be 3.9 at 20% clogged.  
**D)** Total pressure drop equals 0.9 x 3.9 = 3.51 psid when 20% clogged.

### Example #2

**Strainer Size:** 8"  
**RPA Model:** T150FSBW1  
**Filtration:** 5/32" Perf.  
**Flow rate:** 1000 GPM  
**Service:** Water  
**% Clogged:** 60%

- A)** Using Figure #4 the pressure drop is determined to be 0.9 psid with RPA's standard screen.  
**B)** Looking at page 24 we find that the % Open area (OA) of 5/32" Perf. is 58%.  
**C)** Using Chart #1 we read the correction factor to be 0.65 for 5/32" Perf.  
**D)** Total clean pressure drop equals 0.9 x 0.65 = 0.59 psid.  
**E)** Since a non-standard screen is being used, we must calculate the Ratio free area to pipe area.  
**F)** Looking at page 35 we find A<sub>g</sub> = 167 in<sup>2</sup>, A<sub>p</sub> = 50.03 in<sup>2</sup>.  
**G)** The ratio free area to pipe area is calculated as 1.9:1. (2:1 approx.)  
**H)** Using Chart #4 we read the correction factor to be 3.7 at 60% clogged.  
**I)** Total pressure drop equals 0.59 x 3.7 = 2.2 psid when 60% clogged.

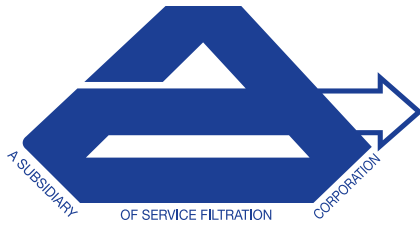

### Basket Strainer Burst Pressure Chart

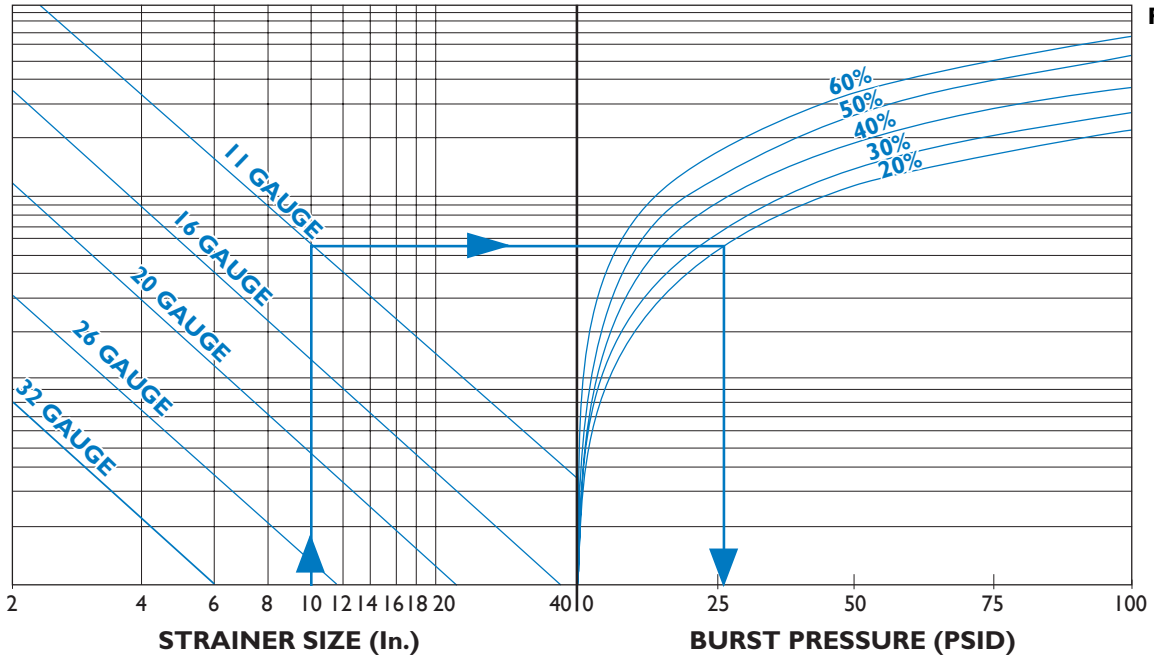

FIGURE 7

**Notes:** 1. The above chart is to be used for strainers manufactured from perforated plate and is based on the formula:

$$t = d \sqrt{\frac{0.3P}{S}}$$

- t = Thickness of perforated plate, in.
- d = Dimension B (See page 4), in.
- P = Burst Pressure, psi
- S = Reduced allowable stress, psi

SOURCE: ASME Section VIII, Div. 1., UG-34.

2. The above chart is based on RPA's standard dimensions. Higher burst pressure ratings are available. Please contact factory.
3. The above chart is based on a screen material of stainless steel. No safety factor is incorporated. It is the responsibility of the user to determine an acceptable safety factor.
4. See page 24 for % Open Areas of RPA's inventoried perforated plate.

#### Example:

**Strainer Size:** 10"  
**Screen Thickness:** 11 gauge  
**Screen Material Open Area:** 20%

- Locate Strainer size.
- Follow vertical line to gauge thickness.
- Follow horizontal line to required perforation open area.
- Follow vertical line downwards to read burst pressure.
- Burst pressure equals 27 psid.

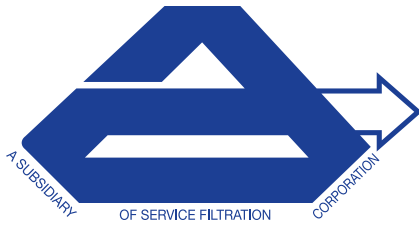

# Engineering Data RPA Series TC Strainer Burst Pressure

## Conical Strainer Burst Pressure Chart

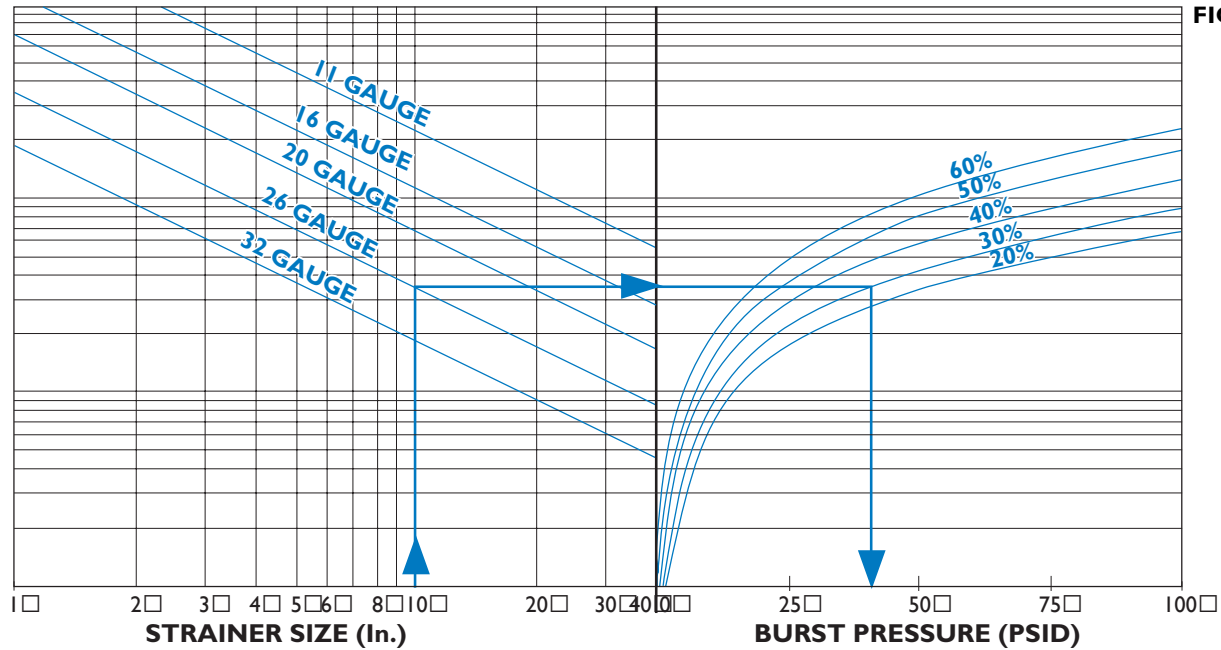

FIGURE 8

**Notes:** 1. The above chart is to be used for strainers manufactured from perforated plate and is based on the formula:

$$P = \frac{2St \cos \alpha}{D + 1.2t \cos \alpha}$$

SOURCE: ASME Section VIII, Div. I., Appendix I.

P = Burst Pressure, psi.  
S = Reduced allowable stress  
t = Thickness of perforated plate, in.  
D = Dimension B (See page 4), in.  
 $\alpha$  = 15 degree

2. The above chart is based on RPA's standard dimensions. Higher burst pressure ratings are available. Please contact factory.
3. The above chart is based on a screen material of stainless steel. No safety factor is incorporated. It is the responsibility of the user to determine an acceptable safety factor.
4. See page 24 for % Open Areas of RPA's inventoried perforated plate.

### Example:

**Strainer Size:**

10"

**Screen Thickness:**

26 gauge

**Screen Material Open Area:**

30%

- Locate Strainer size.
- Follow vertical line to gauge thickness.
- Follow horizontal line to required perforation open area.
- Follow vertical line downwards to read burst pressure.
- Burst pressure equals 41 psid.



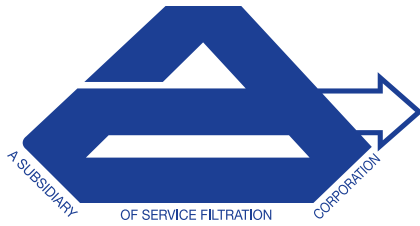

# Engineering Data Y-Strainer Screen Burst Pressure

## Y-Strainer Burst Pressure Chart

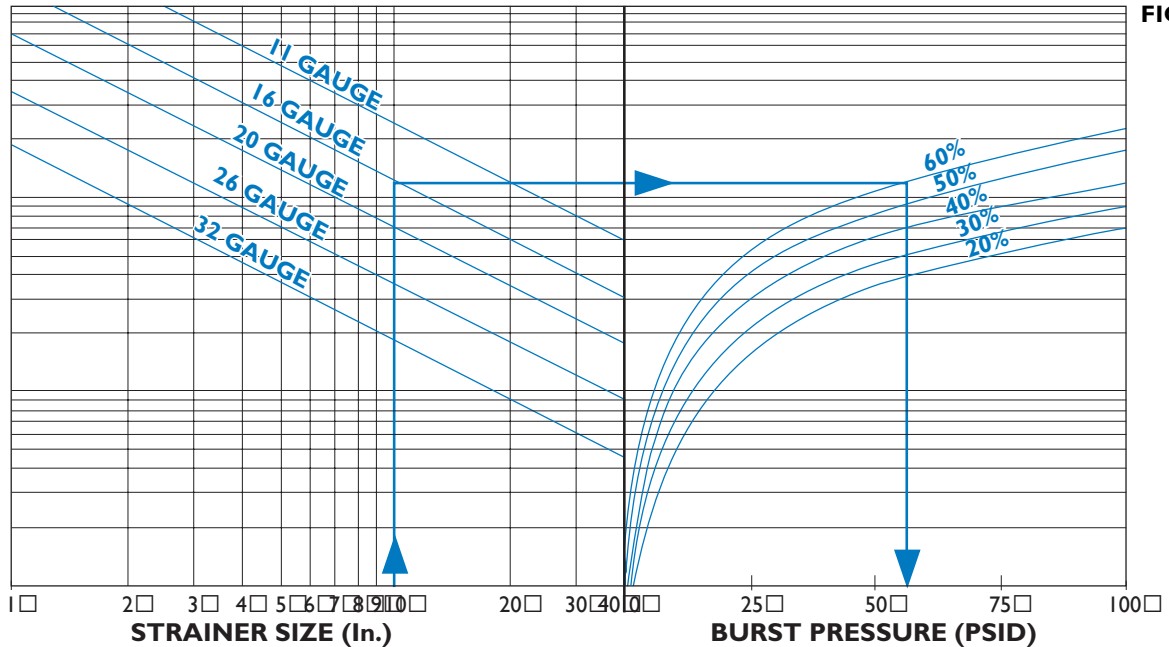

FIGURE 9

**Notes:** 1. The above chart is to be used for strainers manufactured from perforated plate and is based on the formula:

$$P = \frac{St^2}{R - 0.4t}$$

P = Burst Pressure, psi  
S = Reduced allowable stress, psi  
t = Thickness of perforated plate, in.  
R = Outside radius of screen, in.

SOURCE: ASME Section VIII, Div. I., Appendix I.

2. The above chart is based on RPA's standard dimensions. Higher burst pressure ratings are available. Please contact factory.
3. The above chart is based on a screen material of stainless steel. No safety factor is incorporated. It is the responsibility of the user to determine an acceptable safety factor.
4. See page 24 for % Open Areas of RPA's inventoried perforated plate.

### Example:

**Strainer Size:** 10"  
**Screen Thickness:** 16 gauge  
**Screen Material Open Area:** 60%

- Locate Strainer size.
- Follow vertical line to gauge thickness.
- Follow horizontal line to required perforation open area.
- Follow vertical line downwards to read burst pressure.
- Burst pressure equals 56 psid.

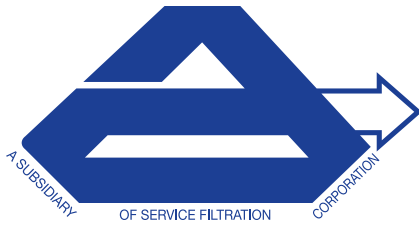

# Engineering Data Tee Strainer Screen Burst Pressure

## Tee Strainer Screen Burst Pressure Chart

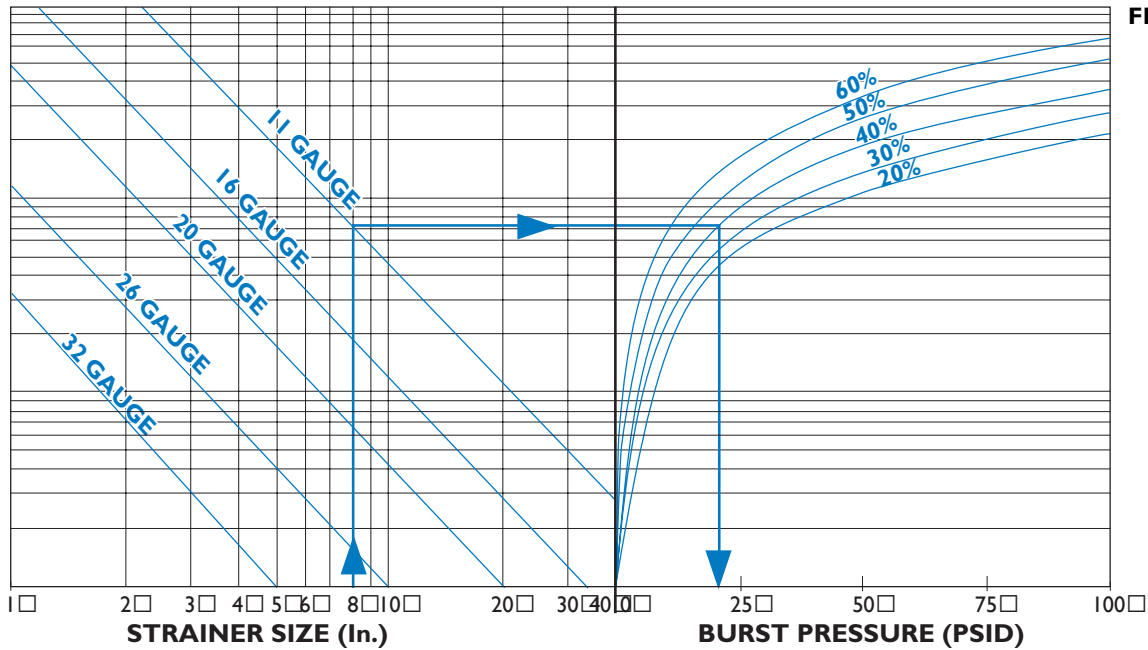

FIGURE 10

**Notes:** 1. The above chart is to be used for strainers manufactured from perforated plate and is based on the formula:

$$t = d \sqrt{\frac{0.3P}{S}}$$

t = Thickness of perforated plate, in.  
d = Basket Diameter, in.  
P = Burst Pressure, psi  
S = Reduced allowable stress, psi

SOURCE: ASME Section VIII, Div. 1., UG-34.

3. The above chart is based on RPA's standard dimensions. Higher burst pressure ratings are available. Please contact factory.
4. The above chart is based on a screen material of stainless steel. No safety factor is incorporated. It is the responsibility of the user to determine an acceptable safety factor.
5. See page 24 for % Open Areas of RPA's inventoried perforated plate.

### Example: #1

**Strainer Size:** 8"  
**Screen Thickness:** 11 gauge  
**Screen Material Open Area:** 40%

- Locate Strainer size.
- Follow vertical line to gauge thickness.
- Follow horizontal line to required perforation open area.
- Follow vertical line downwards to read burst pressure.
- Burst pressure equals 20 psid.

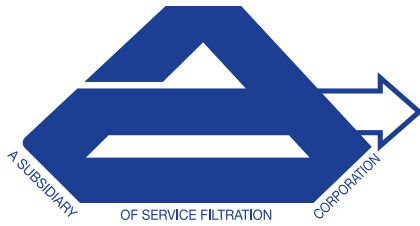

# Engineering Data Basket and Duplex Strainer Basket Burst Pressure

## Basket and Duplex Strainer Basket Burst Pressure Chart

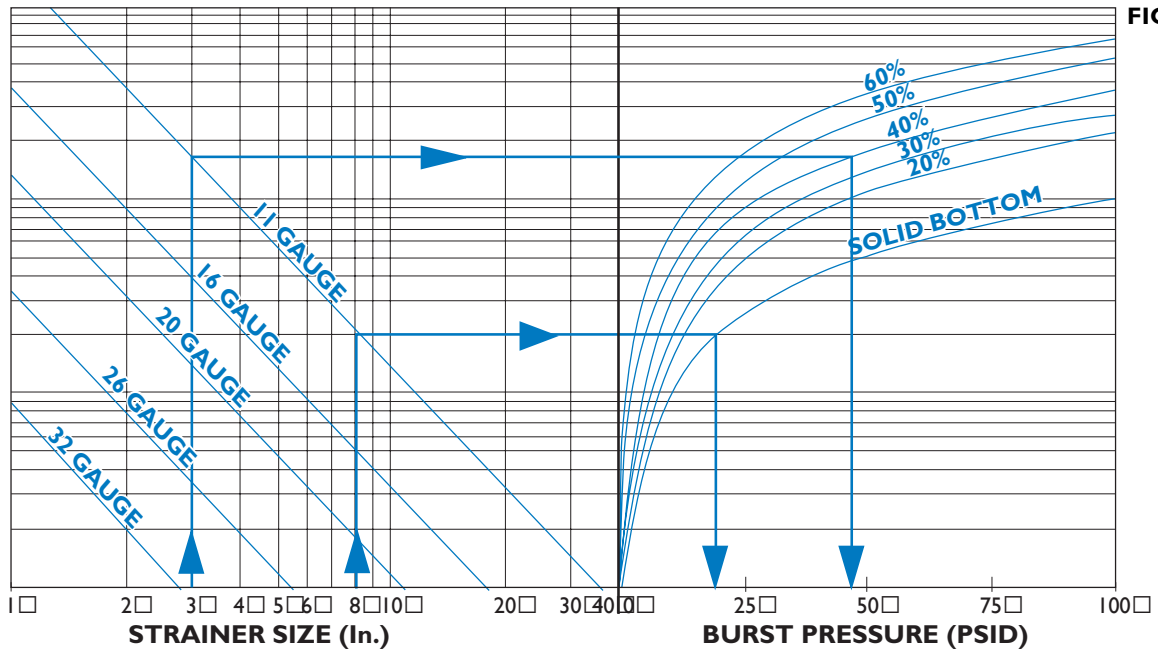

FIGURE 11

**Notes:** 1. The above chart is to be used for strainers manufactured from perforated plate and is based on the formula:

$$t = d \sqrt{\frac{0.3P}{S}}$$

SOURCE: ASME Section VIII, Div. I., UG-34.

t = Thickness of perforated plate, in.  
d = Basket Diameter, in.  
P = Burst Pressure, psi  
S = Reduced allowable stress, psi

2. As standard, RPA supplies baskets with perforated bottoms.
3. The above chart is based on RPA's standard dimensions. Higher burst pressure ratings are available. Please contact factory.
3. The above chart is based on a screen material of stainless steel. No safety factor is incorporated. It is the responsibility of the user to determine an acceptable safety factor.
5. See page 24 for % Open Areas of RPA's inventoried perforated plate.

### Example: #1

**Strainer Size:** 8"  
**Basket Type:** Perforated screen with 11 gauge solid flat bottom  
**Screen Material Open Area:** 20% - 60%

- Locate Strainer size.
- Follow vertical line to solid thickness.
- Follow horizontal line to solid bottom curve.
- Follow vertical line downwards to read burst pressure.
- Burst pressure equals 19 psid.

### Example: #2

**Strainer Size:** 3"  
**Basket Type:** 11 gauge perforated screen with 11 gauge perforated flat bottom.  
**Screen Material Open Area:** 40%

- Locate Strainer size.
- Follow vertical line to gauge thickness.
- Follow horizontal line to 40% Open Area curve.
- Follow vertical line downwards to read burst pressure.
- Burst pressure equals 44 psid.

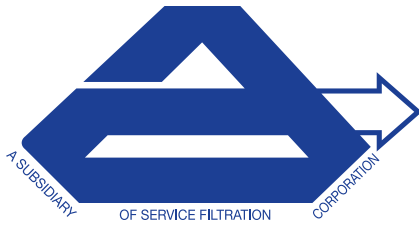

# Engineering Data Fabricated Strainer Screen Effective Areas

## Fabricated Strainer Screen Effective Areas

Strainer Type	Pipe Size (In.)	Std. Opening (in.)	Nominal Area of Sch. 40 / Std. Pipe (Sq. In.)	Gross Screen Area (Sq. In.)	Free Area (Sq. In.)	Ratio Free Area to Pipe Area
Y (Style #1)	2	0.125	3.36	39	16	4.6
Y (Style #1)	3	0.125	7.39	77	31	4.2
Y (Style #1)	4	0.125	12.73	135	54	4.2
Y (Style #1)	5	0.125	20.01	160	64	3.2
Y (Style #1)	6	0.125	28.89	215	86	3.0
Y (Style #1)	8	0.125	50.03	375	150	3.0
Y (Style #1)	10	0.125	78.85	545	218	2.8
Y (Style #1)	12	0.125	113.10	785	314	2.8
Y (Style #1)	14	0.188	140.50	900	360	2.6
Y (Style #1)	16	0.188	185.66	1210	484	2.6
Y (Style #1)	18	0.188	237.10	1560	624	2.6
Y (Style #1)	20	0.188	294.83	1950	780	2.6
Y (Style #1)	24	0.188	429.13	2765	1106	2.6
T (Style #1)	2	0.125	3.36	22	9	2.6
T (Style #1)	2.5	0.125	4.79	25	10	2.1
T (Style #1)	3	0.125	7.39	40	16	2.2
T (Style #1)	4	0.125	12.73	58	23	1.8
T (Style #1)	5	0.125	20.01	82	33	1.6
T (Style #1)	6	0.125	28.89	105	42	1.5
T (Style #1)	8	0.125	50.03	167	67	1.3
T (Style #1)	10	0.125	78.85	235	94	1.2
T (Style #1)	12	0.125	113.10	330	132	1.2
T (Style #1)	14	0.188	140.50	420	168	1.2
T (Style #1)	16	0.188	185.66	510	204	1.1
T (Style #1)	18	0.188	237.10	640	256	1.1
T (Style #1)	20	0.188	294.83	780	312	1.1
T (Style #1)	24	0.188	429.13	1060	424	1.0
B (Style #1)	2	0.125	3.36	215	86	25.6
B (Style #1)	3	0.125	7.39	265	106	14.3
B (Style #1)	4	0.125	12.73	265	106	8.3
B (Style #1)	5	0.125	20.01	380	152	7.6
B (Style #1)	6	0.125	28.89	560	224	7.8
B (Style #1)	8	0.125	50.03	570	228	4.6
B (Style #1)	10	0.125	78.85	910	364	4.6
B (Style #1)	12	0.125	113.10	1300	520	4.6
B (Style #1)	14	0.188	140.50	1600	640	4.6
B (Style #1)	16	0.188	185.66	1830	732	3.9
B (Style #1)	18	0.188	237.10	2290	916	3.9
B (Style #1)	20	0.188	294.83	2800	1120	3.8
B (Style #1)	24	0.188	429.13	4090	1636	3.8
DB (Style #1)	2	0.125	3.36	215	86	25.6
DB (Style #1)	3	0.125	7.39	265	106	14.3
DB (Style #1)	4	0.125	12.73	265	106	8.3
DB (Style #1)	5	0.125	20.01	380	152	7.6
DB (Style #1)	6	0.125	28.89	560	224	7.8
DB (Style #1)	8	0.125	50.03	570	228	4.6
DB (Style #1)	10	0.125	78.85	910	364	4.6
DB (Style #1)	12	0.125	113.10	1300	520	4.6
DB (Style #1)	14	0.188	140.50	1600	640	4.6
DB (Style #1)	16	0.188	185.66	1830	732	3.9
DB (Style #1)	18	0.188	237.10	2290	916	3.9
DB (Style #1)	20	0.188	294.83	2800	1120	3.8
DB (Style #1)	24	0.188	429.13	4090	1636	3.8

- Notes:**
1. Values shown are approximate. Contact factory for exact ratios.
  2. Values shown are for strainers with standard screens.
  3. The ratio free area to pipe area may be increased by changing perf. stagger or by using heavy wire mesh.

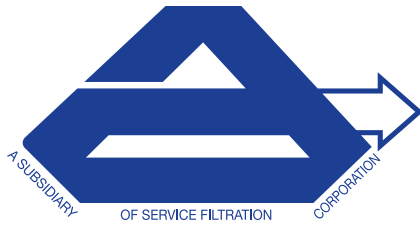

# Check List and Suggested Specifications For RP Adams Inc.

**Strainer Check List:** When selecting a strainer, please take the factors listed below into account. This will assist us when recommending a strainer to suit your specific requirements. Please photocopy this page and fill out the pertinent information.

1. Fluid to be strained \_\_\_\_\_
2. Flow rate \_\_\_\_\_
3. Density of fluid \_\_\_\_\_
4. Viscosity of fluid \_\_\_\_\_
5. Fluid working pressure \_\_\_\_\_  
Maximum pressure \_\_\_\_\_
6. Fluid working temp. \_\_\_\_\_  
Maximum temp. \_\_\_\_\_
7. Preferred material of strainer construction \_\_\_\_\_  
\_\_\_\_\_
8. Present pipeline size & material \_\_\_\_\_
9. Nature of solids to be strained out \_\_\_\_\_
10. Size of solids to be strained out \_\_\_\_\_  
Size of mesh or perf. req. \_\_\_\_\_
11. Clearance Limitation Above \_\_\_\_\_ Below \_\_\_\_\_  
Left side facing inlet \_\_\_\_\_ Right side facing inlet \_\_\_\_\_
12. Maximum pressure drop with clean screen \_\_\_\_\_
13. Expected cleaning frequency \_\_\_\_\_
14. Any other information deemed relevant \_\_\_\_\_  
\_\_\_\_\_  
\_\_\_\_\_  
\_\_\_\_\_  
\_\_\_\_\_

## Suggested Specifications

The strainer shall be a basket strainer and have \_\_\_\_\_ (size) inlet/outlet connections. The end connections shall be (flanged, threaded etc.) and the body shall be complete with a \_\_\_\_\_ (bolted, quick-opening, etc.) cover assembly. The strainer shall be suitable for \_\_\_\_\_ PSIG operating pressure at \_\_\_\_\_ °F operating temperature. The body shall be constructed of \_\_\_\_\_ (body material) while the screen shall be constructed of \_\_\_\_\_ (basket or screen material). A mesh lining of \_\_\_\_\_ (size of mesh) is required, allowing a maximum pressure drop of \_\_\_\_\_ psig. The strainer shall be equipped with a \_\_\_\_\_ (gasket material) gasket and the strainer screen shall be able to withstand \_\_\_\_\_ psig differential pressure without any deformation.

Strainers shall be RPA Model # \_\_\_\_\_ or approved equivalent.

Name \_\_\_\_\_  
 Company \_\_\_\_\_  
 Address \_\_\_\_\_  
 City/Town \_\_\_\_\_  
 State \_\_\_\_\_ Zip Code \_\_\_\_\_  
 Telephone (\_\_\_\_\_) \_\_\_\_\_  
 Fax (\_\_\_\_\_) \_\_\_\_\_

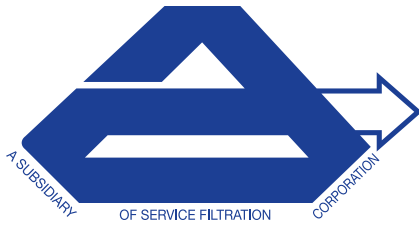

# Installation and Maintenance Instructions for RPA Fabricated Strainers

## 1.0 Strainer Installation Instructions

- A. Ensure all machined surfaces are free of defects and that the inside of the strainer is free of foreign objects.
- B. For horizontal and vertical pipelines, the strainer should be installed so that the drain connection is pointed downwards.
- C. For flanged end strainers, the flange bolting should be tightened gradually in a back and forth clockwise motion.
- D. Threaded end strainers should use an appropriate sealant.
- E. Once installed, increase line pressure gradually and check for leakage around joints.
- F. If the strainer is supplied with a start-up screen, monitor pressure drop carefully.

## 2.0 Screen Removal Instructions (Y, Basket, T and Duplex)

- A. Drain piping (For Duplex Strainers, isolate required chamber).
- B. Vent line to relieve pressure.
- C. Loosen cover and open to access screen.
- D. Remove, clean and replace screen in original position (Note: In some instances, a high pressure water jet or steam may be required for effective cleaning)
- E. Inspect cover gasket for damage. If necessary, replace. (Note: If spiral wound gaskets have been used, they must be replaced and can not be used again).
- F. Tighten cover. The strainer is ready for line start-up.

**CAUTION SHOULD BE TAKEN DUE TO POSSIBLE EMISSION OF PROCESS MATERIAL FROM PIPING. ALWAYS ENSURE NO LINE PRESSURE EXISTS WHEN OPENING COVER.**

## 3.0 Maintenance Instructions

For maximum efficiency, determine the length of time it takes for the pressure drop to double that in the clean condition. Once the pressure drop reaches an unacceptable value, shut down line and follow the "Basket Removal Instructions" above.

A pressure gauge installed before and after the strainer in-line will indicate pressure loss due to clogging and may be used to determine when cleaning is required.

## 4.0 Trouble Shooting Guides and Diagnostic Techniques

- A. After pressurizing, inspect cover and other joints for leakage. Gasket replacement or cover tightening is necessary if leakage occurs.
- B. If the required filtration is not taking place, ensure the basket is installed in the correct position, that being flush to the basket seating surfaces.

## 5.0 Limited Warranty

All products are warranted to be free of defects in material and workmanship for a period of one year from the date of shipment, subject to the limitations below: If the purchaser believes a product defective, the purchaser shall:

- A. Notify the manufacturer, state the alleged defect and request permission to return the product.
- B. If permission is given, return the product with transportation prepaid. If the product is accepted for return and found to be defective, the manufacturer will, at its discretion, either repair or replace the product, f.o.b. factory, within 60 days of receipt, or refund the purchase price.

**Other than to repair, replace or refund described above, the purchaser agrees that the manufacturer shall not be liable for any losses, costs, expenses or damages of any kind arising out of the product, its use, installation or replacement, labeling, instructions, information or technical data of any kind, description of product use, sample or model, warnings or lack of foregoing. No other warranties, written or oral, expressed or implied, including the warranties of fitness for a particular purpose and merchantability, are made or authorized. No affirmation of fact, promise, description of product use or sample or model shall create any warranty from the manufacturer, unless signed by the president. These products are not manufactured, sold or intended for personal, family or household purposes.**

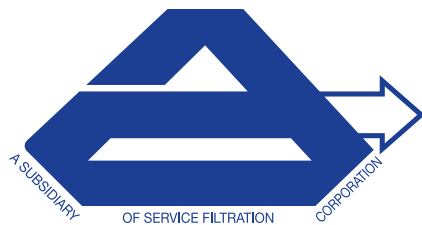

# How To Order

<b>Size In.</b>	8"
<b>Strainer Type</b>	TC = Conical Temporary Strainer TB = Basket Temporary Strainer TP = Plate Temporary Strainer Y = Y-Strainer T = Tee Strainer B = Basket Strainer DB = Duplex Strainer
<b>ANSI Pressure Class</b>	125, 150, 300, 600, 900, 1500
<b>Connection Type</b>	WFN = Wafer Flat Face (Smooth Finish) WFS = Wafer Flat Face (Serrated Finish) WRS = Wafer Raised Face (Serrated Finish) WRTJ = Wafer Ring Joint T = NPT Threaded SW = Socket Weld F = Flanged (RF or FF depending on standard of construction) BW = Buttweld RTJ = Ring Joint G = Grooved
<b>Body Material</b>	I = Cast Iron S = Carbon Steel SS4 = 304 Stainless Steel SS6 = 316 Stainless Steel LC = Low Temperature Carbon Steel * Other materials available upon request
<b>Cover Type</b>	B = Bolted Cover (Gasket Seal) BD = Bolted Cover (Gasket Seal) with Davit H = Swing Bolt Hinged Cover (O-ring Seal) Y = Yoke Cover (O-Ring Seal) T = Quick-Opening Threaded Cover (O-ring Seal) C = Quick-Opening C-Clamp Cover (O-Ring Seal) G = Grooved * Not applicable for temporary strainers
<b>Construction Type</b>	W = Welded C = Cast
<b>Style</b>	* Style 1 will be supplied if style not specified <b>TB, TC, TP Strainers</b> 1 = Flow inside to outside 2 = Flow outside to inside 3 = Bi-directional flow -100 = 100% open area -150 = 150% open area -200 = 200% open area -300 = 300% open area <b>Y Strainers</b> 1 = One style only <b>T Strainers</b> 1 = Inline Flow 2 = 90 degree angle flow - one direction only 3 = 90 degree angle flow - bi-directional <b>B (Basket) Strainers</b> 1 = Inline oversized body 2 = Offset oversized body 3 = Inline standard capacity body 4 = Offset standard capacity body 5 = Inline UL listed <b>DB (Duplex) Strainers</b> 1 = Inline manifold construction 2 = Inline elbow construction 3 = Offset compact face to face
<b>Specials / Other</b>	1 = Non-standard screen 2 = Non-standard gasket 3 = Special external coating 4 = Special internal coating 5 = NACE MR01-75 Compliance 6 = Special N.D.E. 7 = Code stamped (CRN) 8 = Code stamped (U, UM) 9 = Other Special
<b>A</b>	
<b>B</b>	
<b>C</b>	
<b>D</b>	
<b>E</b>	
<b>F</b>	
<b>G</b>	
<b>H</b>	
<b>I</b>	

# Value Added Flow Control Products For All Industries.



**R.P. ADAMS**

A SUBSIDIARY OF SERVICE FILTRATION CORPORATION

**R. P. Adams Company, Inc.**

P.O. Box 963 • Buffalo, NY, 14240

Toll Free: 800-896-8869 • Telephone: 716-877-2608

Fax: 716-877-9385

E-mail: [info@rpadams.com](mailto:info@rpadams.com)